

Operation and Service Manual

300 MHz Dual Inverting Driver Amplifier

SIM954



Revision 1.2 • April 8, 2015

Certification

Stanford Research Systems certifies that this product met its published specifications at the time of shipment.

Warranty

This Stanford Research Systems product is warranted against defects in materials and workmanship for a period of one (1) year from the date of shipment.

Service

For warranty service or repair, this product must be returned to a Stanford Research Systems authorized service facility. Contact Stanford Research Systems or an authorized representative before returning this product for repair.

Information in this document is subject to change without notice.

Copyright © Stanford Research Systems, Inc., 2008 – 2015. All rights reserved.

Stanford Research Systems, Inc.
1290–D Reamwood Avenue
Sunnyvale, CA 94089 USA
Phone: (408) 744-9040 • Fax: (408) 744-9049
www.thinkSRS.com • e-mail: info@thinkSRS.com

Printed in U.S.A.

Document number 9-01649-903



SIM954 300 MHz Dual Inverting Driver Amplifier

Contents

General Information	iii
Safety and Preparation for Use	iii
Notation	iii
Specifications	iv
1 Operation	1 – 1
1.1 Quick Start	1–2
1.2 Operation Inside the SIM900 Mainframe	1–2
1.3 Operation Using an External Power Supply	1–3
1.4 Interfaces	1–4
2 General properties	2 – 1
2.1 DC Characteristics	2–2
2.2 AC Characteristics	2–4
2.3 Noise	2–8
2.4 Crosstalk	2–9
2.5 Isolation	2–10
2.6 Power Supply and Thermal Considerations	2–12
3 Application notes	3 – 1
3.1 Resistive Loads	3–2
3.2 Capacitive Load Handling	3–3
3.3 Inductive Loads	3–5
3.4 Transformers	3–8
3.5 Load Impedance Matching Examples	3–10
3.6 Bridge Configuration	3–11
3.7 Typical Application: a High Voltage Isolated, Low Noise, DC-DC Converter	3–12
3.8 Common Mode EMI/EMF	3–16
3.9 Overdrive Behavior	3–18
3.10 Miscellaneous Loads	3–20
4 Calibration	4 – 1
4.1 Getting Ready	4–1
4.2 Offset Voltage and Input Bias Current	4–1

5	Circuitry	5-1
5.1	Circuit Description	5-2
5.2	Parts Lists	5-4
5.3	Schematic Diagrams	5-7

General Information

The SIM954 300 MHz Amplifier, part of Stanford Research Systems' Small Instrumentation Modules family, is a dual, inverting, precision wideband amplifier with up to ± 10 V output voltage and 1 A output current.

The module can be used to drive many types of light laboratory loads which exceed the capacity of typical instrument outputs without imposing the limitations and cost of typical high power RF amplifiers.

Safety and Preparation for Use

The front-panel BNCs are all grounded to Earth ground, the power-line-outlet ground, and the metal chassis of the module. No dangerous voltages are generated by the SIM954. However, if a dangerous voltage is externally applied to the module, it may be present on all BNC connectors, the chassis, the SIM interface connector, and may cause injury or death.

The SIM954 is a single-wide module designed to be used inside the SIM900 Mainframe. Do not turn on the power until the module is completely inserted into the mainframe and locked in place.

Specifications

Performance Characteristics

Property	Min	Typ	Max	Remarks
Gain		-4 (12dB)		3% max. gain error
-3dB Bandwidth		300 MHz		small signal
Gain Flatness			1 dB	DC to gain peak
Crosstalk			-60 dB -40 dB	at 1 MHz full BW
VSWR		1.2 : 1 1.6 : 1		DC to 100 MHz DC to 300 MHz
Isolation		-70dB -40dB		Output to input DC to 1MHz Output to input DC to 300MHz
Slew Rate	4000 V/ μ s			
Output Amplitude	10 V			into 50 Ω
Peak Output Current	1 A			into $\leq 7 \Omega$
Average Output Current	500 mA			one channel or sum of both channels
Output Impedance		3.3 Ω		
Input Impedance		50 Ω		
Input Offset Voltage			1 mV	user trimmable
Input Bias Current			10 μ A	user trimmable
Operating Temperature	0		40°C	
Power Supply Voltages		-15 V,+15 V		
Supply Current			± 1 A	Internally current limited

Table 1: SIM954 Specifications

1 Operation

Following is a short overview on general guidelines for the operation of the SIM954.

In This Chapter

1.1 Quick Start	1-2
1.2 Operation Inside the SIM900 Mainframe	1-2
1.3 Operation Using an External Power Supply	1-3
1.4 Interfaces	1-4
1.4.1 SIM Interface Connector	1-4
1.4.2 Direct Interfacing	1-4

1.1 Quick Start

The SIM954 contains two mostly independent, identical small RF power amplifiers with a gain of -4 (12dB) into 50Ω and a -3dB bandwidth of 300MHz . The output voltage limit of $\pm 10\text{V}$ can be achieved with a modest $\pm 2.5\text{V}$ input voltage, so most test equipment can drive a SIM954 channel to its voltage and power limits.

The module was specifically designed to drive laboratory loads like magnetic coils, capacitors, piezoelectric and electrochemical cells, small motors, heaters etc.. While these loads often require currents and voltages beyond the range of many test instruments, driving them with expensive and bulky power amplifiers generally does not represent a satisfactory and efficient solution.

Unlike many power amplifiers, the SIM954 can operate as a precise DC amplifier, wideband RF amplifier and driver stage for difficult passive loads like ceramic capacitors and high Q resonant circuits. It will stay unconditionally stable under a variety of load conditions, and its specifications will deteriorate in a predictable manner.

The two otherwise independent amplifier channels share a common power supply and are limited by the total power consumption permissible for a single wide SIM module. See section 2.6 on page 2 – 12 for further discussion.

1.2 Operation Inside the SIM900 Mainframe

The SIM954 is primarily designed to work inside a SIM900 mainframe. Unlike all other SIM modules, however, the SIM954 may under certain circumstances be “hot-plugged” into an operating SIM900 mainframe under power. The SIM954 contains unique power-on circuitry to support stand-alone operation. This circuitry, however, interferes with the SIM900 power supply’s soft-start design. As a result, only two SIM954 modules can reliably be turned on within a SIM900. An allowable work-around to this is to first turn on the SIM900 mainframe, and then “hot plug” additional SIM954 modules into vacant slots of the SIM900, one by one. *This procedure is only recommended for the SIM954, and may not be used with any other SIM module.*

Because of their higher current requirements, the number of SIM954 operated in a single SIM900 mainframe should be limited to a maximum of four. The modules should be separated by at least one slot from each other, and any other module next to a SIM954 should not have an increased power consumption itself.

SIM modules with higher power consumption, like the SIM965 Ana-

log Filter and the SIM940 Rubidium Frequency Standard, should not be operated next to a SIM954 .

Running at its power limit, a SIM954 can heat up to approximately 50°C. Some low power SIM modules like the SIM928 Battery Isolated Voltage Source (because of its temperature sensitive NiMH batteries), can not tolerate these temperatures and should not be operated in a slot next to a SIM954 .

Precision SIM modules like the SIM910 and SIM911 Preamplifiers, the SIM918 Precision Current Amplifier, the SIM921 AC Resistance Bridge, the SIM922 and SIM923 Temperature Monitor modules and the SIM970 Quad Voltmeter might show increased temperature drift when operated close to a SIM954 amplifier and would likely benefit from being thermally isolated from a SIM954.

As with any other power amplifier, loads should be connected and disconnected with the amplifier powered down to ensure safe operating conditions for the SIM954 and the load.

Loads should be checked for their ability to handle the voltage, current and power output limits of the SIM954 .

Many BNC style 50 Ω loads, terminators and attenuators, power splitters, mixers, etc., are at risk of being damaged by a SIM954 if no further precautions against overload are taken.

1.3 Operation Using an External Power Supply

Unlike other SIM modules, the SIM954 has additional power supply filtering and protection against inverse polarity conditions and is therefore somewhat more forgiving when used with custom power supplies. A well regulated, low noise, bipolar power source with ± 15 V, ± 1 A output current can be used to power a SIM954 module.

As with any product that relies on external power, the user is responsible to ensure that the supply never exceeds the maximum operating voltage, that short circuit currents are limited, and that thermal overload is avoided.

Any SIM954 used outside of a mainframe should be kept in a well controlled thermal environment where none of the ventilation slots are covered and the sides are at least one inch away from any other surface.

In this manual it is assumed that the SIM954 is used inside a SIM900 Mainframe. The specifications of the module always refer to use inside a SIM900 mainframe.

1.4 Interfaces

There are a total of four BNCs on the SIM954 front panel. The upper two are the input and output of Channel 1, and the lower two are the input and output of Channel 2. The front panel calls out the input impedance of $50\ \Omega$, the output impedance of $3.3\ \Omega$ and the nominal gain of -4 (12 dB) into a $50\ \Omega$ terminated load.

Each channel has an overload indicator, and there is a single "On" LED on the front panel to indicate that operating voltage is applied to the module. This is useful when the module is used outside of the SIM900 mainframe. The "On" LED does not indicate, however, that the power supply voltage is correct and the power source has sufficient output current to power the module under all load conditions.

1.4.1 SIM Interface Connector

The DB-15 SIM interface connector carries all the power and communications lines to the instrument. The connector signals are specified in Table 1.1.

There is no microcontroller inside the SIM954 and the module does not communicate over its serial port. However, the status/service request line (-STATUS) serves as an indicator for an overload condition which can be detected by the mainframe or the user. This signal will be pulled to ground during an overload condition. The duration of the pull-down state is approximately the same as the on-time of the front-panel overload LED (approximately 0.5s).

All other RS-232 signals are unused.

1.4.2 Direct Interfacing

The SIM954 is intended for operation in the SIM900 Mainframe, but users may wish to directly interface the module to their own systems without the use of the mainframe.

The mating connector needed is a standard DB-15 receptacle, such as Tyco part # 747909-2 (or equivalent). Clean, well-regulated supply voltages of -15 and $+15$ VDC must be provided, following the pin-out specified in Table 1.1. Ground must be provided on pins 1 and 8, with chassis ground on pin 9. The -STATUS signal may be monitored on pin 2 for a low-going TTL-compatible output indicating an overload condition.

The SIM954 has internal protection against reverse polarity, but there is no overvoltage protection on these power supply pins.

Pin	Signal	Direction Src ⇒ Dest	Description
1	SIGNAL_GND	MF ⇒ SIM	Ground reference for signal
2	-STATUS	SIM ⇒ MF	Status/service request (GND = asserted, +5 V= idle) (Overload condition indicator)
3	RTS	MF ⇒ SIM	HW Handshake (+5 V= talk; GND = stop)(No connection in SIM954)
4	CTS	SIM ⇒ MF	HW Handshake (+5 V= talk; GND = stop)(No connection in SIM954)
5	-REF_10MHZ	MF ⇒ SIM	10 MHz reference (No connection in SIM954)
6	-5 V	MF ⇒ SIM	Power supply (No connection in SIM954)
7	-15 V	MF ⇒ SIM	Power supply
8	PS_RTN	MF ⇒ SIM	Power supply return
9	CHASSIS_GND		Chassis ground
10	TXD	MF ⇒ SIM	Async data (start bit = "0" = +5 V; "1" = GND) (No connection in SIM954)
11	RXD	SIM ⇒ MF	Async data (start bit = "0" = +5 V; "1" = GND) (No connection in SIM954)
12	+REF_10MHz	MF ⇒ SIM	10 MHz reference (No connection in SIM954)
13	+5 V	MF ⇒ SIM	Power supply (No connection in SIM954)
14	+15 V	MF ⇒ SIM	Power supply
15	+24 V	MF ⇒ SIM	Power supply (No connection in SIM954)

Table 1.1: SIM Interface Connector Pin Assignments, DB-15

The power supply must be able to provide both supply voltages simultaneously at 1A load without significant dropout.

Failure to comply with these requirements may lead to malfunction and possibly destruction or lasting deterioration of the module's performance.

The SIM954 may present a significant reverse current into the power supply when turned off or when subjected to faulty load conditions. Other loads on the same power supply can be put at risk by this behavior, and if necessary, additional isolation and protection in the form of reverse diodes, zener overvoltage protection diodes, and voltage regulators has to be established.

The SIM954 power is internally well filtered, but it is recommended to use another set of RF beads and ceramic filter capacitors directly on the DB-15 receptacle in noise sensitive environments.

This is a standard measure for all RF amplifiers and is especially important with an RF module like the SIM954 which can deliver up to 1A of output current.

2 General properties

In this chapter general properties of the SIM954 are being discussed.

In This Chapter

2.1	DC Characteristics	2-2
2.1.1	DC Gain	2-2
2.1.2	Gain Error	2-2
2.1.3	Offset Voltage and Input Offset Current	2-2
2.2	AC Characteristics	2-4
2.2.1	Input Characteristics	2-4
2.2.2	AC Gain	2-5
2.3	Noise	2-8
2.4	Crosstalk	2-9
2.5	Isolation	2-10
2.6	Power Supply and Thermal Considerations	2-12

2.1 DC Characteristics

Unlike most medium and high frequency amplifiers, the SIM954 does not compromise DC and low frequency properties to achieve its performance at high frequencies. It behaves very much like an ideal amplifier with finite output resistance for a wide range of loads and operating conditions.

2.1.1 DC Gain

The DC gain of each SIM954 channel is -4 or (12 dB) into $50\ \Omega$. This gain is load dependent. Since the amplifier has an output resistance of $3.3\ \Omega$, the following formula describes the effective gain for a given resistive load:

$$Gain(R_{load}) = -4.264 \times \frac{R_{load}}{R_{load} + 3.3\ \Omega} \quad (2.1)$$

In particular, an unterminated SIM954 will have a DC gain of -4.264 (12.6 dB), which is 6.6% higher than the nominal terminated gain.

If the SIM954 is used to drive a $75\ \Omega$ system, the expected DC gain is $Gain(75\ \Omega) = -4.084$ (12.2 dB).

2.1.2 Gain Error

The typical gain error of a SIM954 channel is approximately 1%, and the worst case error can be up to $\pm 3\%$. With exception of a few applications, even the worst case gain error is of little consequence.

Gain errors need to be considered when two or more SIM 954 channels are connected in parallel. The two amplifiers can differ by up to 6% in their absolute DC gain, and for 10 V output amplitude this is equivalent to a 0.6 V output voltage difference.

Since this voltage difference appears across the two $3.3\ \Omega$ output resistors, a current of up to $0.6\ \text{V}/6.6\ \Omega \approx 90\ \text{mA}$ can flow between the two amplifier outputs reducing the static SIM954 current limit of 500 mA by approximately 18%.

The majority of amplifiers will have lower gain errors and the standard deviation for the cross current is only 30 mA under mentioned circumstances.

2.1.3 Offset Voltage and Input Offset Current

With a factory calibrated input offset voltage of less than 1 mV and an input offset current of less than $10\ \mu\text{A}$, a DC precision of better than 2 mV (input referenced) can be achieved in $50\ \Omega$ systems.

Users who wish to re-calibrate the input offset voltage and the input offset current can use the procedure described in Chapter 4. Depending on the temperature range the SIM954 is exposed to, this procedure may slightly improve the input offset voltage.

2.2 AC Characteristics

2.2.1 Input Characteristics

The SIM954 has outstanding AC input characteristics up to about 100 MHz with input VSWR not exceeding 1.2 : 1. Between 100 MHz and 300 MHz, the amplifier's input impedance falls to a minimum of $30\ \Omega$ and a worst case VSWR of 1.6 : 1. At the worst frequency, which is just slightly above the $-3\ \text{dB}$ point, the input has a 0.25 reflection coefficient or $-12\ \text{dB}$ return loss. Since the non-ideal input

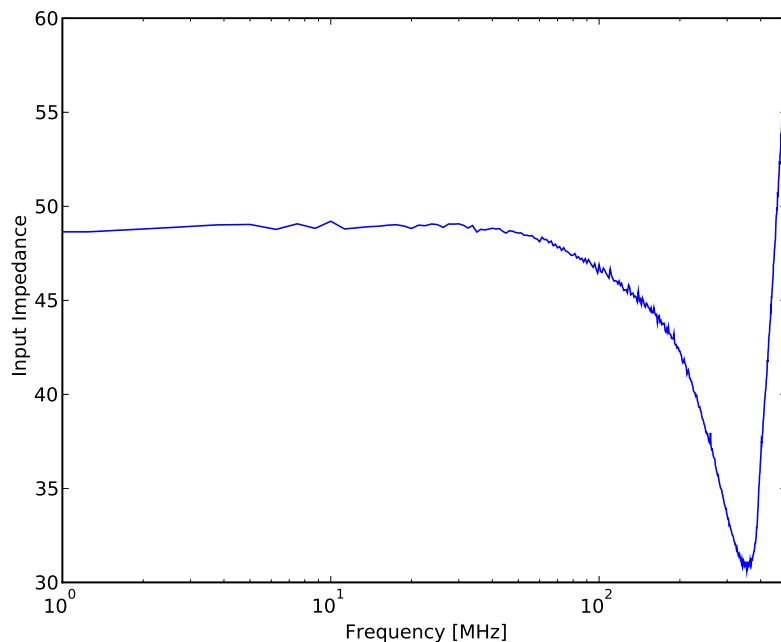

Figure 2.1: Typical SIM954 input impedance

impedance will reflect part of the incoming signal energy at high frequencies, it is necessary to either terminate the source output or keep the cable to the SIM954 input short. To maintain the best possible pulse response at 300 MHz ($\lambda_{RG58} = 0.67\text{m} = 26''$) the maximal cable length is 8.3 cm or 3.3'', which is a $\lambda/8$ cable.

Short cables are especially important when two or more SIM954 channels are being connected in series because the driving SIM954 channel is *not* terminated. While two SIM954's connected in series by a 4'' cable will still have an acceptable pulse response, the same combination used with 12'' cables will exhibit significant ringing due to cable reflections.

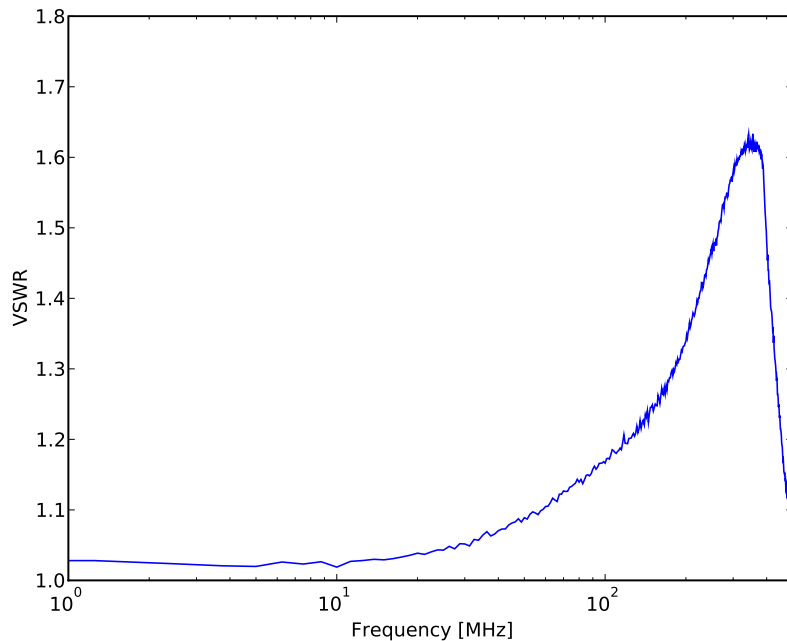

Figure 2.2: Typical SIM954 input VSWR

If optimal response at the end of an electrically long cable driven by a nonideal source is of importance, an input attenuator can be used to optimize the amplifier's input impedance near the upper end of its frequency range. By trading gain flatness against absolute gain, satisfactory results can usually be achieved even with electrically long cables.

2.2.2 AC Gain

The typical AC gain is very flat up to about 10 MHz and will exhibit variations of ± 0.2 dB up to 100 MHz. Beyond 100 MHz the gain will slightly peak (< 1 dB or 12% in amplitude). Beyond the peak it will fall off and reach its -3 dB point at about 300 MHz.

These gain variations depend on the internal compensation of the op-amps (which are production lot dependent) and the tolerances of the gain setting resistors in the SIM954. Since the THS3091 op-amps used in this module are transimpedance types, the gain peaking and the -3 dB point are controlled by the feedback resistor.

The curves shown are based on a randomly chosen SIM954 prototype and are characteristic for the product. However, SRS does not test for the worst gain variation with a precision that resembles the plots

shown. The gain variation guaranteed by design and our calibration procedure assure that the gain will stay within ± 1 dB of the ideal. If a more precise knowledge of the gain and phase over some part or all of the frequency range is required, the user can perform such a measurement with a suitable vector network analyzer on the module of interest. This is especially important at high frequencies where the input and output impedance will interact with the driver and load impedance and cause reflections on cables. All measurements are taken by suppressing the input mismatch with a 10dB attenuator directly at the SIM954 input.

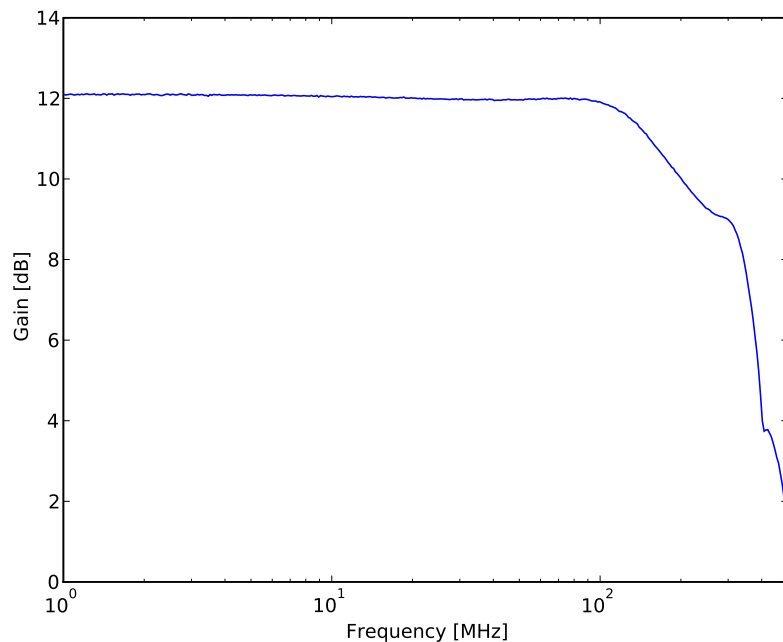

Figure 2.3: Typical SIM954 gain plot

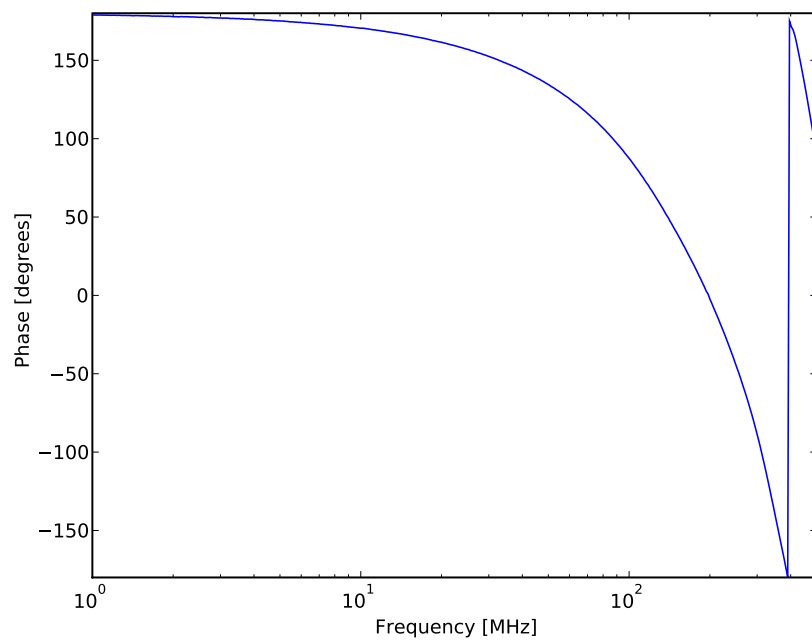

Figure 2.4: Typical SIM954 phase plot

2.3 Noise

The SIM954 amplifier stages are compound amplifiers. The RF power amplifier contains four THS9031 current-feedback operational amplifiers per channel. These amplifiers have $2 \text{ nV}/\sqrt{\text{Hz}}$ typical equivalent input voltage and $14 \text{ pA}/\sqrt{\text{Hz}}$ typical current noise (Johnson noise above 100 kHz) each. The parallel operation effectively halves the input voltage noise and doubles the current noise. Amplifier noise accounts for $1 \text{ nV}/\sqrt{\text{Hz}}$ and $28 \text{ pA}/\sqrt{\text{Hz}}$ input noise. The resulting noise matching resistance of $1 \text{ nV}/\sqrt{\text{Hz}}/28 \text{ pA}/\sqrt{\text{Hz}} = 36 \Omega$ is very close to the source resistance, and the amplifier noise contribution is low.

Including the feedback resistors, this compound amplifier can be calculated to have a theoretical Johnson noise floor of $1.95 \text{ nV}/\sqrt{\text{Hz}}$ when driven with a 50Ω source.

Noise measurements on SIM954 stages have yielded Johnson noise data between $1.85 \text{ nV}/\sqrt{\text{Hz}}$ and $2.45 \text{ nV}/\sqrt{\text{Hz}}$. The lower figure was obtained at 100 MHz, while the larger number coincides with slightly higher noise at 160 MHz. The increase in noise (gain) at higher frequencies can be attributed to the increasing (capacitive) mismatch of the SIM954 input to the driving impedance and parasitic impedances in the amplifier's feedback. The chosen compensation optimizes a combination of gain flatness, bandwidth and step response and sacrifices noise performance close to the bandwidth limit.

The SIM954's Johnson noise is better than $3 \text{ nV}/\sqrt{\text{Hz}}$ for amplifiers driven by 50Ω sources.

The resulting noise figure for the ideal amplifier is about 8 dB, while the guaranteed noise figure does not exceed 11 dB. Actual production models will be somewhere in-between.

Because of its relatively low gain and medium noise figure, the SIM954 does not qualify as a low noise amplifier, but it will still yield reasonable noise performance in applications which can tolerate its modest 11 dB noise figure while requiring only small gains at large amplitudes, a domain which is usually poorly covered by other amplifiers.

2.4 Crosstalk

The two channels of a SIM954 module are not shielded from each other and exhibit crosstalk. Because of the geometric asymmetry of the module, the output of Channel 1 is closer to the input of Channel 2 than vice versa. The crosstalk will generally be higher from Channel 1 than Channel 2. This should be taken into account in applications which require the least amount of interference between the two channels. The worst crosstalk is caused by a resonance in

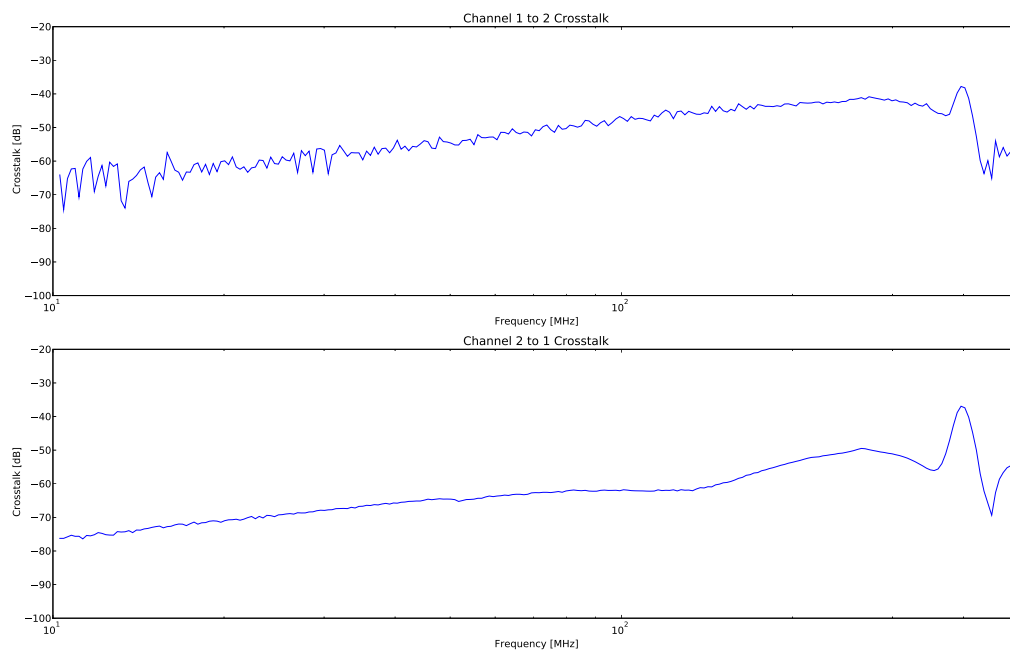

Figure 2.5: SIM954 Crosstalk

the module's power plane in conjunction with the operational amplifier's diminishing common mode rejection ratio at high frequencies. Since the frequency of this resonance is at approximately 385MHz, it is well above the amplifier's guaranteed bandwidth limit. Under normal circumstances it should be of little concern.

2.5 Isolation

Because each SIM954 channel is an inverting current feedback amplifier, the input node is connected via an effective $\approx 50 \Omega$ resistor to the virtual ground node of the amplifier, which itself is connected to the output via an effective $\approx 220 \Omega$ feedback resistor.

Because the amplifier's transimpedance gain is finite, the isolation between the output and the input port is also finite. As the loop gain diminishes at higher frequencies, the output to input isolation will decrease, and a larger fraction of the RF energy at the output will appear at the input of the amplifier.

While this is generally of limited concern, it can become a problem if this RF energy can leak into high gain or high Q (quality factor) circuits connected to the amplifier input.

High impedance, high Q resonant circuits (e.g. tanks, open transmission lines, crystals etc.) can be excited, and oscillation of the amplifier and the frequency selective element can occur. Limited isolation properties are more likely to become a problem if the output is incorrectly terminated as well, where the load reflects RF energy back into the amplifier. Since the phaseshift between input and output changes at higher frequency, making the feedback more "positive," parasitic oscillations due to limited isolation are most likely to occur near the amplifier's bandwidth limit.

When multiple amplifiers are connected in series to increase the gain, or used in parallel to increase output current or voltage in a bridge circuit, the finite isolation can destabilize the amplifiers even in wideband, low Q circuits. Again these oscillations are most likely going to occur at frequencies close to the amplifier's bandwidth limit (i.e., in the 100 MHz to 300 MHz range).

If oscillations (or an increase in noise gain) are observed, isolation between the amplifier and the driving or terminating circuits has to be increased. This can be accomplished with attenuators (to reduce overall gain), isolating power splitters (to isolate multiple inputs) or by using frequency selective circuits like lowpass and bandpass filters (to reduce gain at the highest frequencies at which isolation is worst).

The following diagram shows the measured isolation between a SIM954 output and its input. The measurement was made with a network analyzer by connecting the source to the amplifier's output and the network analyzer input to the amplifier's input.

Both the isolation in amplifier 'on' and amplifier 'off' configuration are shown. With the amplifier powered on, the isolation gets increas-

ingly worse at higher frequencies, while with the amplifier off it gets increasingly better. At the highest frequency (500 MHz), well above the amplifier's bandwidth, both curves converge to roughly the same value, which is essentially a measure of the parasitic impedances of the amplifier's feedback path.

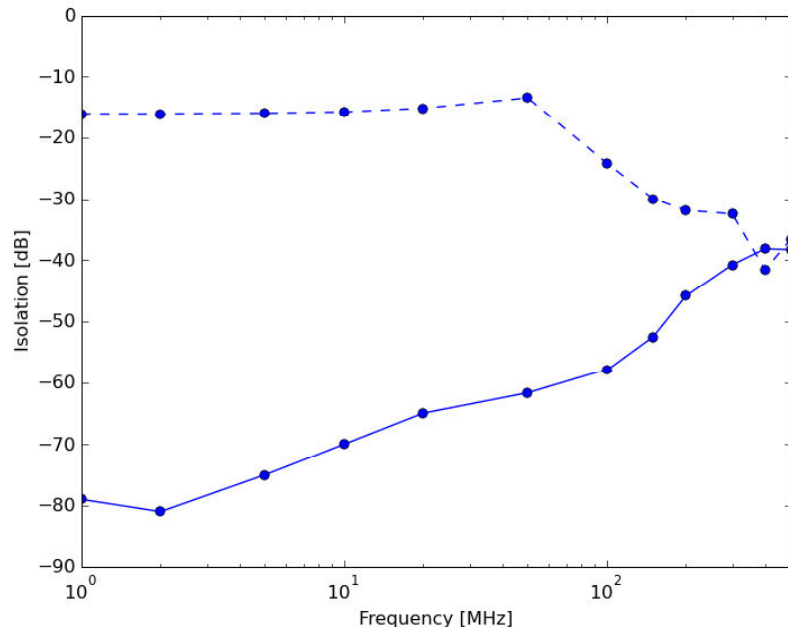

Figure 2.6: SIM954 output to input isolation. The dashed line represents power-off isolation, the solid line represents the powered state. The curves are interpolated between measured data (dots).

2.6 Power Supply and Thermal Considerations

A SIM954 module can initially draw up to 750 mA of power supply current from both ± 15 V rails of the SIM900 mainframe. It is therefore recommended that you limit the number of SIM954 modules to four per mainframe to stay within the 3 A power supply limits.

If two or more modules are used in one mainframe, they should not be placed in adjacent slots, and SIM954s should not be placed next to temperature sensitive modules like the SIM928 or SIM965. A SIM954 can degrade the temperature drift of other SIM modules, and care should be taken to avoid such configurations in applications that rely on the precision of the SIM system.

These amplifiers can generate more heat by design than a single wide module can conduct to the mainframe. In the worst case, a SIM954 can dissipate close to 25 W of power. However, since the internal power supply circuit has a negative thermal feedback, the module will quickly reduce the power consumption to 15 W by limiting the supply current to about 500 mA.

The main cooling mechanism of the module is conductive and the heat will flow towards the front panel which will get noticeably warm (up to 50°C or 130°F) for a module operated in a 25°C environment. Higher environmental temperatures can lead to thermal shutdown of the op-amps and highly distorted signal waveforms in modules which are driven to their full power limits. The thermal shutdown is reversible and will not lead to longterm damage of the operational amplifiers. However, the built-in electrolytic decoupling capacitors will degrade if the module's internal temperature is near or above 50°C for hundreds or thousands of hours.

Temperatures on the front-panel BNCs that are uncomfortable to the touch are a good indicator that the module is being used above its long-term power handling capability.

3 Application notes

In This Chapter

In this chapter properties and limits of the amplifier and its performance in typical applications are discussed.

3.1	Resistive Loads	3-2
3.2	Capacitive Load Handling	3-3
3.2.1	Capacitive Reverse Currents	3-4
3.3	Inductive Loads	3-5
3.3.1	DC Current and Inductor Saturation	3-6
3.3.2	Inductive Voltage Spikes	3-7
3.4	Transformers	3-8
3.4.1	Input Side Transformer	3-8
3.4.2	Power Splitter and Bridge operation	3-8
3.4.3	Output Side Transformer	3-9
3.5	Load Impedance Matching Examples	3-10
3.6	Bridge Configuration	3-11
3.7	Typical Application: a High Voltage Isolated, Low Noise, DC-DC Converter	3-12
3.7.1	Circuit Description	3-12
3.8	Common Mode EMI/EMF	3-16
3.9	Overdrive Behavior	3-18
3.10	Miscellaneous Loads	3-20
3.10.1	Heaters and Peltier Elements	3-20
3.10.2	Filaments	3-20
3.10.3	Driving Power MOSFETs	3-20
3.10.4	Piezo Elements	3-21
3.10.5	Electric Motors	3-21

3.1 Resistive Loads

The SIM954 can operate on resistive loads ranging from shorts to open outputs.

Because of the finite output resistance and current limit, the amplifier's gain and output voltage swing are load dependent. There are three important cases of load limiting:

- For load impedances below approximately $7.3\ \Omega$, the output voltage is limited by the highest output current of 1 A. This limit is transient (i.e., it can only be reached for short pulses before the internal power supply current limiter reduces the power supply voltage on both amplifiers).
- The continuous average current driving limit is 500 mA from each power supply. Since this is the sum of the average supply currents of both amplifiers on one rail (i.e., either positive or negative), it is possible to drive an average current of +500 mA indefinitely from one amplifier channel and –500 mA from the second, but not the same polarity from both at the same time. This means that the SIM954 will develop its full output power in differential and push-pull configurations. However, care has to be taken not to thermally overload the SIM954 in this mode.
- Finally, load resistances above $18\ \Omega$ limit the output current below both the transient and continuous limits and can be driven for an arbitrarily long time (assuming that the other channel does not overload the power supply current limiter).

The last case implies that for $50\ \Omega$ loads, the SIM954 can drive 10 V into the load on two channels (at 200 mA each), and for higher load impedances the output voltage can rise as high as 10.667 V (for an open output) without overdriving the circuit.

Figure 3.1 shows the maximal output voltage as a function of load resistance.

If the combined output current of both channels exceeds 500 mA to 700 mA of loading on either power supply rail, the built-in power supply current limiter will gradually reduce the power supply voltage available to both amplifiers as the built-in $4400\ \mu\text{F}$ buffer capacitors are discharging. This will be seen as a gradual decrease in output voltage and an increasing level of distortion (clipping). The amplifier should not be operated in this way if signal quality is of importance.

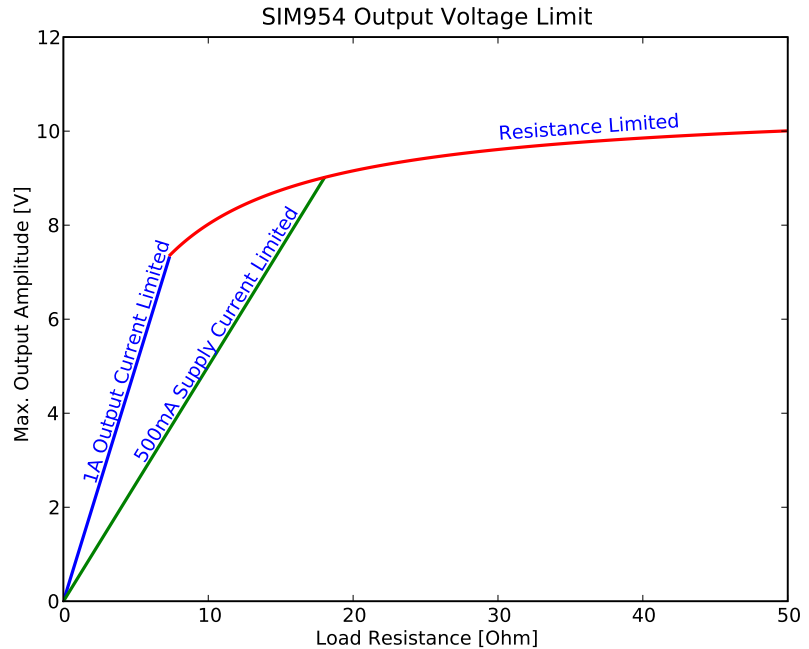

Figure 3.1: SIM954 output voltage limit as a function of load resistance

3.2 Capacitive Load Handling

Because the active part of each SIM954 amplifier channel is isolated from the load by a 3.3Ω series resistor, capacitive loads will limit the amplifier's bandwidth by forming an RC-lowpass filter. The advantage of adding an output resistor to the actual amplifier is that it will remain stable for all possible passive loads. However, the series resistance will also limit the amplifier's bandwidth when driving capacitive loads.

A 100 pF capacitor, which is roughly equal to 1 m (3') of unterminated RG58 coaxial cable, will form an RC-lowpass filter with 330 ps time constant and 480 MHz corner frequency. Above the RC corner frequency, the AC voltage on the capacitive load will fall off with an additional 6 dB/octave, but the amplifier will still be able to drive up to $1 A_{peak}$ AC current into the load.

Capacitive loads larger than 100 pF will severely limit the bandwidth, and in addition will also reduce the slew rate for large scale signals because the amplifier's output current is limited. The SIM954's 1 A current limit leads to an impressive $1000 V/\mu s$ slew rate for 1nF capacitive loads.

When driving fast risetime pulses into small capacitive loads, cable inductance can lead to resonant peaking, as shown in figure 3.2. If flat frequency response below the RC-corner frequency is important, cable lengths and impedances have to be carefully matched to the application. For larger capacitors and electrically short connections, these effects are not important, and the waveforms are similar to those of a pure RC low pass filter as seen in figure 3.3.

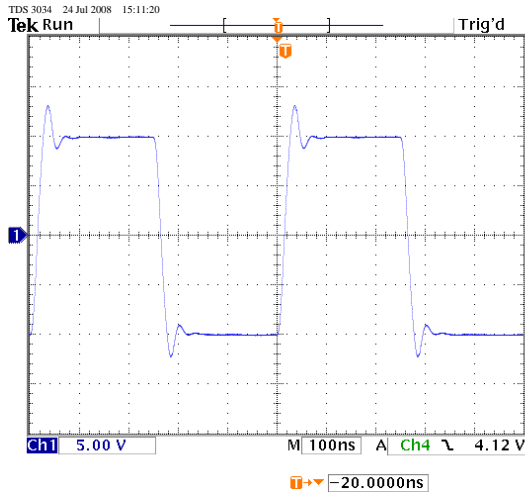

Figure 3.2: The SIM954 driving a 1 nF ceramic capacitor with a 2 MHz square wave to 20 Vpp

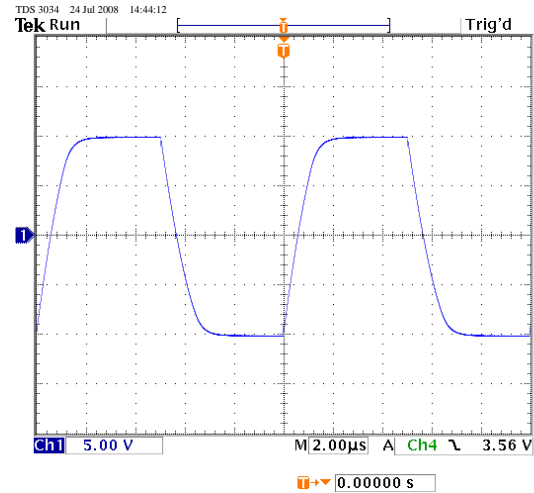

Figure 3.3: The SIM954 driving a 100 nF ceramic capacitor with a 100 kHz square wave to 20 Vpp

3.2.1 Capacitive Reverse Currents

Every capacitor stores a charge equivalent to the product of the applied voltage and its capacitance. This charge can cause a reverse current flow if the amplifier is turned off while it remains connected to a charged capacitor. Since the SIM954 does not guarantee by design that this reverse current won't harm the amplifier or the SIM900 mainframe, caution should be used with circuits which drive large capacitive loads or even electrochemical cells like batteries which can store very large amounts of charge.

If a large reverse current (≥ 10 mA for 1 s) may flow into an unpowered SIM954 the user should consider adding a relay's contact between the module's output and the load. The relay's coil can be powered by the mainframe's ± 5 , ± 15 or $+24$ V or the user supplied voltage to close the circuit only when the SIM954 is under power.

3.3 Inductive Loads

Similar to the case of capacitive loads, inductive loads and the amplifier's finite output impedance form series RL circuits. Such a circuit behaves like a high pass filter with a 3 dB corner frequency of $f = R/2\pi L$.

A 1 μH inductor will form a 525 kHz highpass filter with the 3.3 Ω output resistor. Often, the amplifier will be used to drive inductors above this corner frequency, but this is not always the case.

In Figure 3.4 the amplifier was driving a 1 μH inductor with a 1 MHz square wave with 750 mA_{pp}. The clean RL-highpass response can be easily seen. While the voltage on the inductor goes to almost 0 V, the amplifier is still driving the full current. The highest output voltage in this case was chosen such that the amplifier does not reach its 1 A current limit, and stays in its linear regime. Had a larger driving voltage been applied, the nonlinearity due to the saturation of the output current would have been visible.

Most importantly, since in this case the internal power dissipation is proportional to the output current times the amplifier's power supply voltage, even a 500 mA average current will lead to no less than 7.5 W of additional power dissipation. If such RL highpass filter behavior is observed at high signal levels, a significant amount of heat will be generated in the amplifier. Users need to carefully evaluate the thermal load and the resulting heating of the SIM954 and mainframe when driving inductive loads below their RL-highpass corner frequency.

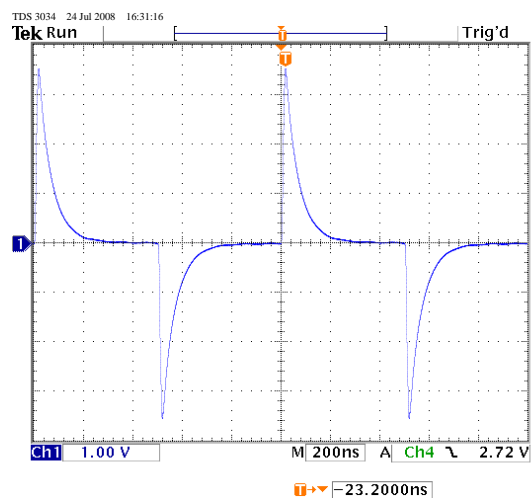

Figure 3.4: The SIM954 driving a 1 MHz square wave with 750 mA peak current into a 1 μH inductor

3.3.1 DC Current and Inductor Saturation

Since inductors are essentially DC shorts, driving even a small DC voltage on an inductor will lead to large DC currents. It is important to verify that the amplifier's current and thermal power dissipation limits are not violated by such a condition, and that the inductor is actually able to handle the output current. Core saturation in inductors wound on iron or ferrite cores should be avoided because of the rapid rise in losses for AC currents in the saturated core.

Figures 3.5 and 3.6 show an example of inductor saturation. The SIM954 is driving an ultra-high permeability core with almost rectangular magnetization curve, used in a fluxgate magnetometer, with a 10 kHz sine wave. The core saturates shortly after the voltage on the coil passes the extremal values. Because of the rapid loss of the core's ability to store any further magnetic energy, the voltage on the coil breaks down, while at the same time the current increases rapidly.

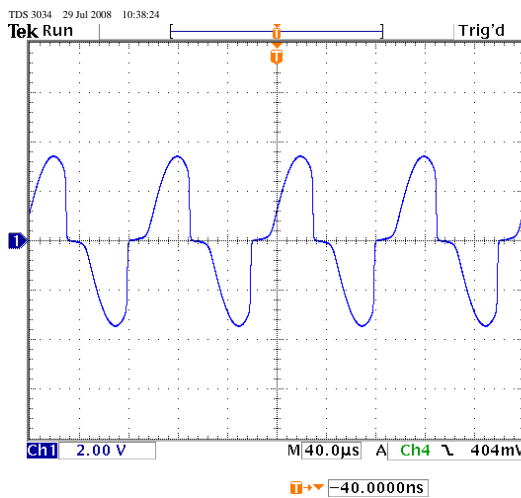

Figure 3.5: Voltage on fluxgate magnetometer coil driven with 10 kHz sine wave

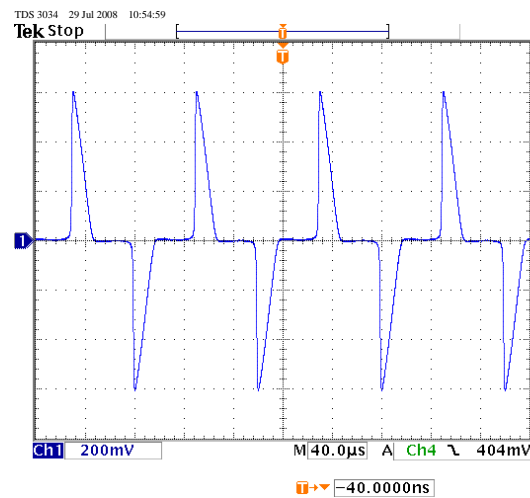

Figure 3.6: Current through fluxgate magnetometer driven with 10 kHz sine wave

Since the voltage at the output of the module goes to zero at the same time the output current rises, a saturated inductor presents a very heavy load to the amplifier. In general it is better to avoid saturating inductors. However, if the SIM954 is used to deliberately drive inductors into saturation, as in the example of the flux gate magnetometer coil, care should be taken to avoid the amplifier's current and thermal limits.

3.3.2 Inductive Voltage Spikes

Every (non-saturated) inductor stores an amount of energy equal to $E = I^2L/2$ in its magnetic field when it is excited by a current I . If the current loop is suddenly opened (e.g. by opening the circuit between the current source and the inductor), this energy will lead to a rapid buildup of voltage across the inductor due to self induction and Lenz's rule. This inductive voltage spike can exceed the safe operating limits of the amplifier's ± 15 V power supply rails and lead to destruction of the amplifier.

Inductive loads should only be plugged in or removed from the amplifier while the power supply is turned off.

If the amplifier is being used as a coil driver, a suitable external voltage protection device (power zener diode, transient voltage suppressor, etc.) should be used.

3.4 Transformers

Transformers are inductive loads which are of great importance in practical applications. The SIM954 has excellent properties in transformer circuits.

Transformers can be connected to both the input and the output of the SIM954, and in many applications such a topology is advantageous.

3.4.1 Input Side Transformer

An input transformer to the SIM954 can, but does not have to be isolated. Autotransformers and wideband transmission line transformers are equally well suited to drive the module.

An input side transformer without a series capacitor will present a DC short to the SIM954. Because of the small input offset current, the additional DC error will be less than 1 mV and is acceptable for most applications. This circuit has the advantage that it guarantees that the output is DC free, which is important if the module has to also drive an output transformer.

The transformer's inductance will form an LC high pass filter with the 50 Ω input impedance of the module. For an RF transformer with 1 μ H secondary winding inductance, the –3 dB corner frequency will be at 7.96 MHz.

It follows that a practical input transformer that covers a lower corner frequency f should have a secondary winding inductance of at least $8 \mu\text{H} \times \frac{f}{\text{MHz}}$. The primary inductance will then be determined by the square of the winding ratios.

3.4.2 Power Splitter and Bridge operation

An input transformer is often used as a 180° power splitter circuit. The two outputs of such a splitter can drive the two SIM954 amplifiers in one module differentially and 180° out of phase.

The two amplifiers will act as a differential driver which has twice the output power of a single channel.

A 180° splitter as shown in figure 3.7 uses a transformer with a single primary and a split secondary winding with a winding ratio of $\sqrt{2} : 1$. At this ratio it matches both input and output impedances to 50 Ω . However, the naive transformer circuit omitting $R1$ would not isolate the two output ports from each other, which can lead to crosstalk and unwanted feedback. Wilkinson¹ proposed the shown

¹ E.J. Wilkinson, "An N-way Power Divider", IRE Trans. on Microwave Theory & Techniques, v8, p116-118 (1960).

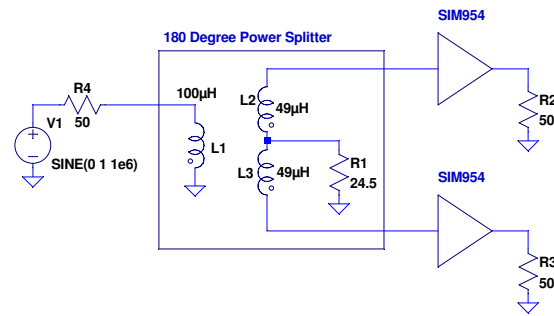

Figure 3.7: 180° power splitter circuit

circuit topology which adds isolation between the two output ports without sacrificing any signal power.

In the properly terminated balanced circuit the center tap node is a virtual ground, and no current will flow through resistor R1. If power is reflected into the transformer by the load on either of the splitter outputs (i.e., in this case the SIM954 inputs), some of it will be transferred to this load resistor and will not be visible at the other output port (although some power will still make it to the input port because the circuit does not have perfect isolation between all ports).

It should be noted that the SIM954 requires an isolated power splitter in differential driver applications. High frequency oscillations have been observed with some non-isolated splitters.

It is convenient to approximate the necessary $\sqrt{2}$ turn ratios with multiples of 7 : 5 or 10 : 7 turn ratios. The resulting matching errors are small and can usually be neglected. And while they do result in a non-ideal isolation characteristics of the circuit, this can (at least theoretically) be reduced by lowering the resistance of the internal isolation resistor from 25 Ω to 24.5 Ω . However, in a typical implementation the difference is likely going to be lost in errors caused by component tolerances and stray impedances.

These phase splitters are commercially available from many sources (e.g., Mini-Circuits), but suitable transformers can also be easily made from toroidal RF cores.

3.4.3 Output Side Transformer

The more interesting and challenging case is operating the SIM954 with an output transformer. Care must be taken that no DC components are present on the circuit's output when driving a transformer directly. This can either be achieved with a DC block like a series capacitor, or by means of an input transformer.

Blocking DC currents protects both the amplifier as well as RF transformers which can be damaged by the amplifier's 1 A output current capability (especially wideband RF transformers which are often wound with very thin wires on small cores).

While series capacitors may also be used as DC blocks on the output, care must be taken that they do not form high Q series resonance circuits with the transformer's winding inductance. The better way to avoid DC voltages is to connect both amplifier inputs and outputs directly to transformers. This adds the least number of poles to the circuit's transfer function and will lead to a benign and well defined frequency response.

In this case, the low DC input offset voltage will lead to an output offset of no more than 5 mV to 10 mV, and the built-in 3.3 Ω output resistance will limit DC output currents to a few milliamps – a value which all but the smallest RF transformers can handle safely and without signal degradation.

The main advantage of transformer coupling is the added possibility of load impedance matching and bridge operation which allow the use of the SIM954 as a small RF power amplifier.

3.5 Load Impedance Matching Examples

The SIM954 is designed to generate up to 1 A output current into low impedances and up to 10 V output voltage into 50 Ω . Because of its low output impedance of 3.3 Ω , however, the amplifier cannot fully drive into a 50 Ω load directly, which would limit the current to approximately $\frac{10V}{50\Omega} = 200$ mA, a factor of five shy of the amplifier's output current limit.

The actual amplifier (without series resistors) will be able to generate 10.6 V before the overload detection circuit indicates an invalid operating state. The most power is available at the output when the actual amplifier produces its highest output voltage and 1 A output current simultaneously.

This is equivalent to a power matched load resistance of 10.6 Ω . By subtracting the internal series resistance of 3.3 Ω from this ideal load, we arrive at an ideal external load of 7.3 Ω . The most power that can be extracted from a single SIM954 channel using a 7.3 Ω load is then $7.3 W_{peak}$.

To match the ideal load to a 50 Ω system, an output transformer with a voltage ratio of $\sqrt{50/7.3} \approx 2.62$ is required. The closest ratios that can be easily achieved with wideband RF transformers which can only have a few turns on either primary and secondary side are:

- 2.5 with 5 : 2 turns,
- $2.\bar{6}$ with 8 : 3 turns,
- 2.75 with 11 : 4 turns and
- 2.4 with 12 : 5 turns.

The 8 : 3 turn transformer will lead to a $7.03\ \Omega$ load impedance as seen by the amplifier (i.e. ,a 1 A output current limit translates into $7\ W_{peak}$ and $4.9\ W_{eff}$ for sinewaves).

3.6 Bridge Configuration

By using both an input and an output transformer, two SIM954 channels can be operated in a bridge configuration, thereby doubling the theoretical output power to $14\ W_{peak}$ and close to $10\ W_{eff}$. The necessary output impedance transformation requires a $\sqrt{50/14.6} \approx 1.85$ ratio. This is best achieved with a 9 : 5 turn ratio for a factor of 1.8.

As in the case of the input splitter, an isolated power combiner should be used (although isolation is not as important as on the input side).

3.7 Typical Application: a High Voltage Isolated, Low Noise, DC-DC Converter

The ability of the SIM954 to drive significant power into a transformer can be used to provide isolated power to circuits under unusual circumstances for which no easy commercial solutions exists. In the following we describe a ± 5 V, 100 mA isolated DC-DC converter with 20 kV isolation. Remarkably, the circuit exhibits less than $50 \mu\text{V}_{\text{rms}}$ output ripple and noise.

3.7.1 Circuit Description

In order to achieve 20 kV isolation voltage with minimal effort, Dearborn 392250 20 kVDC, 150°C UL 3239 Style high voltage wire is used to build a 1:1 isolation transformer on a Fair-Rite 2843009902 dual-aperture core. This large broadband noise suppression core has two 0.250" holes which can accept two turns of the Dearborn high voltage wire. A single loop of wire is used for the primary and a second, isolated loop for the secondary winding. The windings have enough inductance to operate this transformer between 250 kHz and 1 MHz. Toward the lower end of this range, this transformer is limited by its low winding inductance, and above 1 MHz the core losses in the Type 43 material of this core will dominate and limit performance. Other core materials and larger cores, which allow for higher inductance, can extend the frequency range of this design considerably.

The primary winding can be driven directly by the SIM954 through a 50Ω coaxial cable. The cable lengths should not exceed 3' to avoid losses due to mismatched termination. Since neither the SIM954 nor the transformer load are matched to the 50Ω cable impedance, the coax will have a complex impedance.

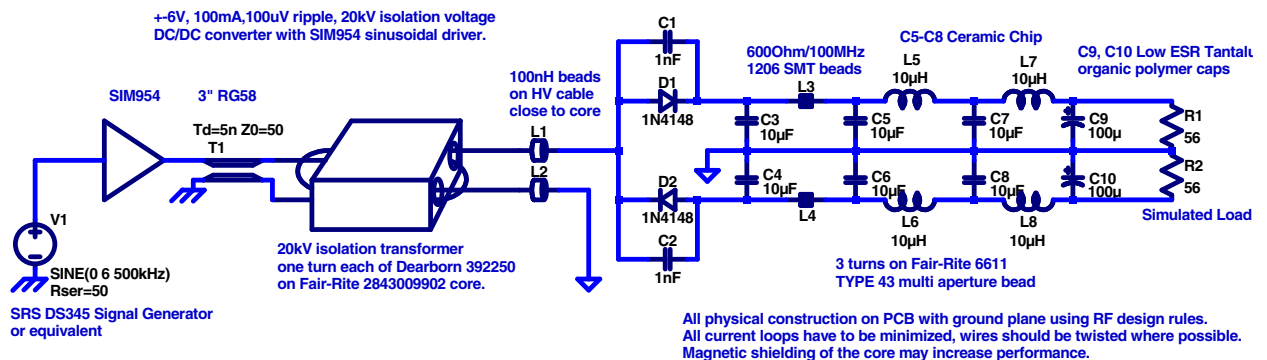

Figure 3.8: Schematic of the 20 kV isolation, sinusoidal drive ultra-low ripple DC-DC converter.

A cable that is physically very short compared to the wavelength

of the driver signal (200 m for 1 MHz on 50 Ω coax) will typically perform best without impedance matching LC-circuits at one or both ends.

The transformer's secondary winding is connected to a simple half-wave rectifier made from fast switching diodes such as the 1N4148.

In order to achieve minimum switching noise, the SIM954 is used to drive the circuit with a sinusoidal voltage rather than a square wave (as in ordinary switching power supply circuits). This ensures that there are no spectral components beside the main operating frequency present at the output of the driver. After the transformer, the switching of the rectifier diodes produces significant switching transients which have to be filtered. $1nF$ capacitors in parallel with the two diodes slow diode turn on and turn off times down. Slower transients significantly reduce noise in comparison to conventional converter circuits where ultrafast diodes are used to achieve highest possible converter efficiency.

The rectified current is filtered by a pair of 10 μF ceramic capacitors followed by two sets of beads and ceramic and Tantalum capacitors. In this circuit, six-aperture through hole beads (Fair-Rite 6611 type 43) were used, but high impedance multi-layer surface mount beads are preferable in applications which are very noise sensitive and have to improve the performance of this demonstration circuit. In general, the lowest ESR (Equivalent Series Resistance) capacitors have to be used. Multiple ceramic capacitors in parallel are much better than a single capacitor with the same equivalent capacitance because the parallel circuit reduces lead inductance and ESR. More capacitance to suppress the fundamental frequency can be added using high quality tantalum or organic electrolyte capacitors.

Multiple consecutive LC filter stages should be used for optimum results, with the first stages using RF beads to suppress the highest frequency components first before rejecting the fundamental frequency and lower harmonics in the later stages. Proper RF design techniques and a ground plane are absolutely necessary to achieve the shown results.

The residual switching noise of this design were mainly dependent on wiring geometry and the size of the current loop outside of the core. If lowest possible switching noise is critical, the magnetic fields from the core and the current loops have to be shielded with suitable RF shields. Use of tightly twisted wires to reduce magnetic coupling is vital. Traces carrying AC currents should be kept short and be routed above a ground plane or sandwiched between two ground planes on inner layers.

If voltage regulation is necessary, low-drop-out voltage regulators

can be used to stabilize the ± 6 V filtered voltage to load independent ± 5 V.

The following output ripple measurements in figures 3.9 and 3.10 illustrate the enormous advantages of sinusoidal drive DC-DC converters.

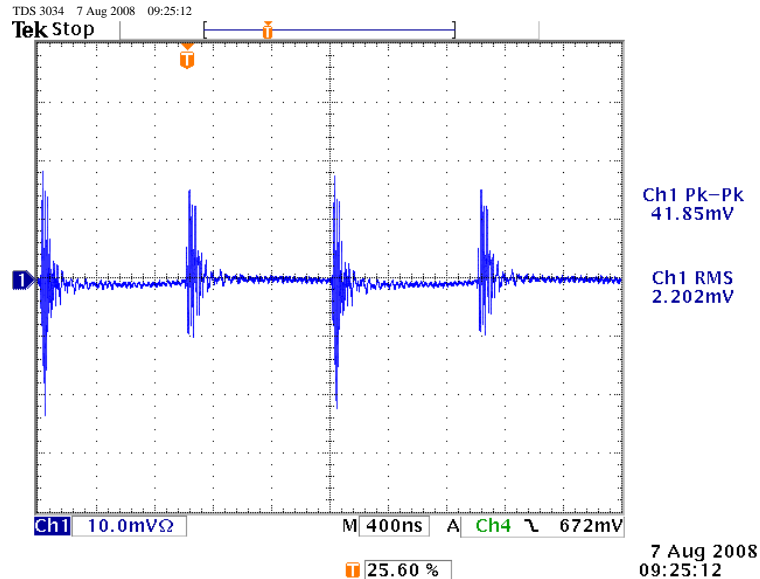

Figure 3.9: Noise measurement for 500 kHz square wave drive producing an output voltage of ± 6 V at 100 mA load. At 10 mV per division vertical oscilloscope gain the effective scale is $400 \mu\text{V}$ per division. Every edge on the driving voltage causes large transients with a peak amplitude of 1.67 mV_{peak} and an RMS amplitude of $88 \mu\text{V}_{rms}$.

All measurements were taken with a SIM914 dual 350 MHz preamp with both channels in series, giving an equivalent gain of $\times 25$ in addition to the oscilloscope's vertical gain.

Most of the spectral energy in the ripple of the sinusoidal drive converter is in the fundamental and second harmonic frequency. Both components can be further reduced by carefully controlling the current loops in the circuit and are by no means optimal. The circuit at this point was so sensitive to wiring geometry that no further reduction was attempted since the ultimate performance will depend on the particular application of this converter. However, one can estimate from the result that peak-peak ripple of $50 \mu\text{V}_{pp}$ and RMS noise on the order of less than $10 \mu\text{V}_{rms}$ is a realistic design goal.

For improved common mode rejection, the transformer should be

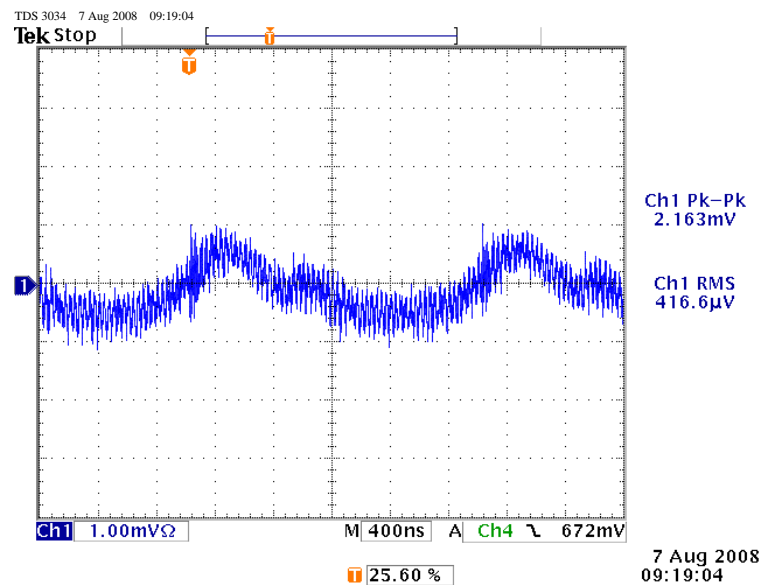

Figure 3.10: The SIM954 driving the same circuit under identical load conditions with a sinusoidal voltage. The sharp transients are almost gone. Please note that the oscilloscope is now set to 1 mV per division, i.e. the effective scale is now $40 \mu\text{V}$ per division. The peak-to-peak amplitude is $87 \mu\text{V}_{pp}$ and the ripple RMS is $17 \mu\text{V}_{rms}$.

driven differentially with two SIM954 channels by using an isolating 180° power splitter on their inputs to make a close to ideal sinusoidal differential driver.

3.8 Common Mode EMI/EMF

All (coaxial) cables have two modes of wave propagation. The differential mode is characterized by the voltage difference being exclusively between the two conductors. In the case of coax, this means the electric and magnetic fields are contained between the inner conductor and the shield. The current on the inner conductor is exactly opposite to the current on the shield. In this mode, coaxial cables are perfectly shielded and do not act as antennas.

Common mode signals, however, are characterized by the inner conductor and the shield being at the same potential, and current on both flowing in the same direction. In this case, there will be a substantial inductive potential drop along the cable which will, in effect, act like a wire antenna of equal dimensions.

In practice, common mode excitation of cables often goes unrecognized because on a properly terminated, ideal, lossless cable the common mode will never be excited. Most theoretical explanations about the function of coaxial cables only take differential mode signals into account and fail to mention the more problematic case of common mode excitation. However, cable losses and improper termination on either the transmitter or receiver end will commonly lead to mode mixing, and some of the signal energy from the desired differential mode will leak and appear as a common mode signal (i.e., radiate an electromagnetic signal into free space from the shield of the cable).

In practice, the EMI (electromagnetic interference) emitted by typical RG58 BNC cable wiring can often lead to noticeable feedthrough, crosstalk, feedback and even oscillations in RF systems with a total signal gain of 60 dB or more.

Since the SIM954 is an amplifier with very low output impedance, amplifier output side termination is poor by design. In addition, the signal gain and the high power of the amplifier increase the likelihood of problematic EMI levels. This is compounded by the fact that the product is specifically designed to drive non-resistive, and ill-terminated loads. In many cases the load will also be insufficiently shielded (e.g., magnetic coils) and present unwanted but efficient antenna characteristics.

To control the possibly severe effects of common mode excitation, we suggest that clip-on cable beads (like the Steward part number 28A0392-0A2 or similar) should be used directly at the output of the amplifier *and* near ill-terminated (i.e., reflective) loads.

These beads are easy to install and can prevent a host of common mode EMI problems generated by the fast and powerful SIM954

amplifier stage, especially in the frequency range above 10 MHz. Any common mode signal will be attenuated by the bead which acts like a lossy inductor and increases the common mode impedance of the cable.

While these beads are most effective for higher frequencies, their frequency range can be extended by running the cable multiple times through a (larger diameter) specimen. This increases the inductance at low frequencies by the number of turns square (i.e., three turns will increase the inductance nine-fold). Bead materials usually have very good RF properties far below the frequency of their highest attenuation and make excellent common mode chokes. The increase of the inductance together with the decrease of damping at lower frequencies can make multi-turn beads resonant with useful Q-factors of approximately 2 to 50. A common exploit of this parallel (and therefore high impedance) self-resonance is to use it to suppress narrow-band noise. It is important to recognize, however, that the bead impedance will turn capacitive above the resonance point, which can lead to unwanted resonance with the cable inductance.

Beads will have no noticeable effect on differential mode signals which have currents that cancel out on the inner conductor and the shield, and therefore generate no magnetic field outside of the cable.

Since these beads have to be installed outside of the module's Faraday shield and are application specific (attenuation at the signal frequency of interest depends on the size and material of the bead), they can not be included into the design of the amplifier. It is the user's responsibility to be aware of these effects and filter properly.

An example of a typical common mode scenario is shown in Figure 3.11 where a SIM954 is driving a 4 V_{pp}, 10 MHz square wave into an 8" long stub antenna. This would be typical of driving a relatively small unshielded coil or similar load. The voltage between the SIM900 mainframe chassis ground and the SIM954 output BNC ground was measured with an oscilloscope with 300 MHz bandwidth with and without a 275 Ω (at 100 MHz) clamp on bead. The same beaded cable (as shown in fig.3.12) radiates significantly less and also reduces the amount of conducted RF on the mainframe ground.

Clip on beads are a simple solution to comply with EMI/EMF requirements but do not guarantee that the radiated emissions of the module are within any specific compliance limits. Double shielding and control of the frequency spectrum of the driving signal might also be necessary.

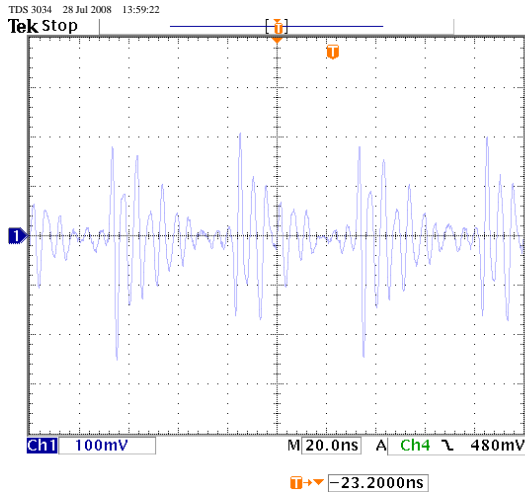

Figure 3.11: Common mode voltage at the amplifier output ground relative to SIM900 mainframe chassis when driving an 8 inch long stub antenna with a 4 V_{pp} square wave at 10 MHz.

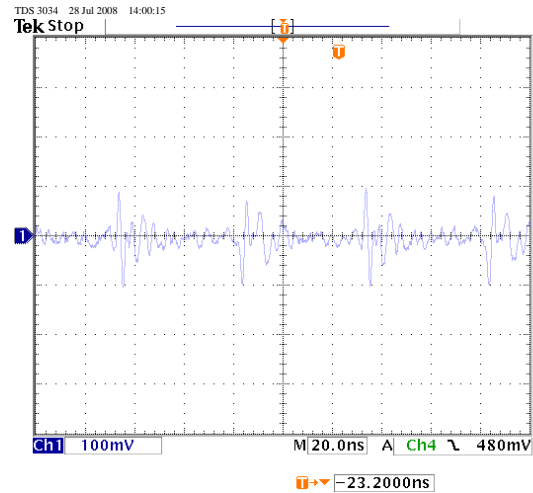

Figure 3.12: Same conditions but with a 275 Ω (at 100 MHz) clamp on cable bead. The peak amplitude has been reduced by approximately 6 dB and the ringing is substantially shorter.

3.9 Overdrive Behavior

The amplifier exhibits different kinds of overdrive behavior depending on load and frequency. The most basic overdrive condition is a voltage overdrive on light load as shown in Figures 3.13 and 3.14.

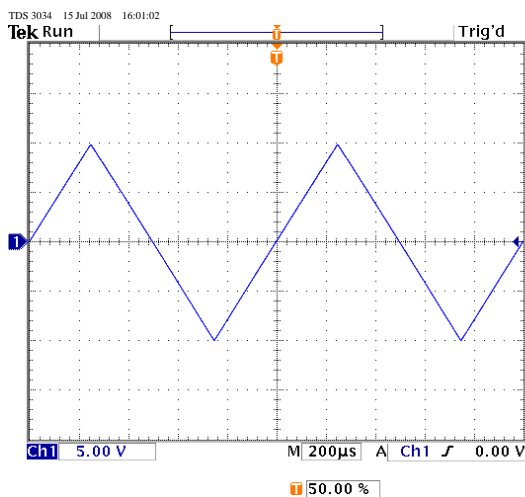

Figure 3.13: The SIM954 driven with 1 kHz triangle wave to 20 V_{pp} into 50 Ω

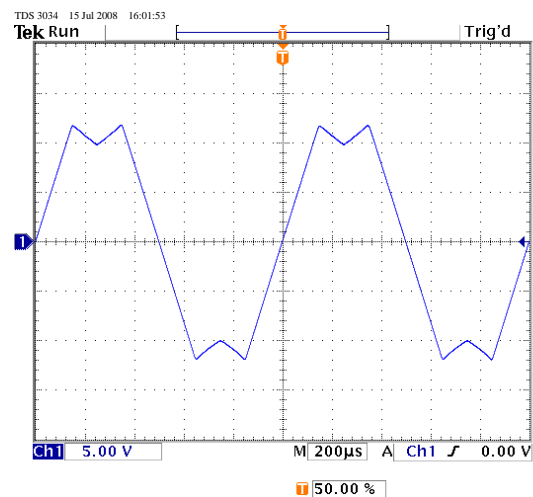

Figure 3.14: The SIM954 overdriven with 1 kHz triangle wave to > 20 V_{pp} into 50 Ω

The signal rectification is a design feature of the circuit and does not indicate a fault condition.

A different kind of soft overdrive behavior happens for low impedance loads when the current limit is reached. In this case, the amplifier will exhibit a monotonic soft clipping behavior as shown in figures 3.15 and 3.16.

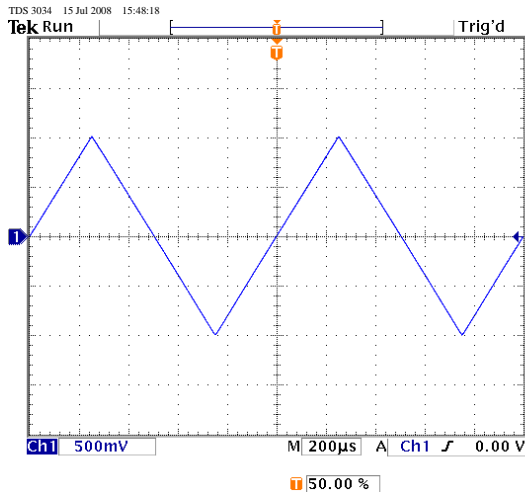

Figure 3.15: The SIM954 driven with 1 kHz triangle wave to $2 A_{pp}$ into 1Ω

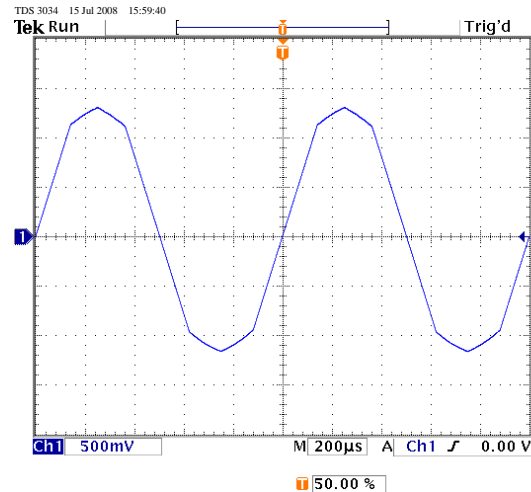

Figure 3.16: The SIM954 overdriven with 1 kHz triangle wave to $> 2 A_{pp}$ into 1Ω

Ultimately, near the safe temperature limit for silicon devices, the temperature protection circuits inside each operational amplifier will engage and shut the device down.

If an application requires hard clipping, we suggest to use the SIM914 Preamplifier or the SIM964 Analog Limiter. The SIM914 will limit at approximately 2 V output signal level. When cascaded with a SIM954, it will result in approximately 8 V of clipping amplitude with 3 ns of input recovery from overload while providing 200 MHz of combined bandwidth while in linear mode.

The SIM964, on the other hand, allows 1 MHz bandwidth and 10 mV resolution for both upper and lower limits.

3.10 Miscellaneous Loads

The SIM954 was specifically designed with difficult laboratory loads in mind. These often include low impedance, resonant, non-linear and time varying loads.

3.10.1 Heaters and Peltier Elements

The SIM954 can be used to drive small (up to approximately 5 W) resistive heaters and Peltier elements in thermal control applications. If the amplifier specifications can potentially exceed the maximum heater or Peltier voltage or current, the user may add external protection circuits to assure the safety of the attached load.

Since this is an RF amplifier, it may be necessary to filter its output voltage with capacitors, inductors, beads or complex LC filters to prevent RF voltages from being radiated by unshielded loads.

3.10.2 Filaments

The SIM954 amplifier can be used to drive low power filaments, but care must be taken to assure that the filament current and voltage limit are not exceeded. Turn-on and turn-off transients depend very much on the power supply configuration and are not limited by design. Sensitive, unprotected filaments can therefore be easily damaged or destroyed.

3.10.3 Driving Power MOSFETs

The SIM954 can be used to drive power MOSFETs with turn-on voltages of less than 10 V, assuming the source of the device is ground referenced.

The switching speed of the MOSFET will depend on its gate charge which is a nonlinear function of the gate voltage. A typical device will exhibit a strong rise of gate charge in a small voltage region around the turn-on voltage.

If the MOSFET is to be driven with a fast rising edge, the current to deliver this charge to the gate can exceed the output current of the amplifier. As a result, there is a minimum turn-on time which depends mostly on the output current capability of the amplifier. For a typical 10 nC gate charge, this would be at least 10 ns (limited by the 1 A output current of the SIM954).

However, since the gate will present a large capacitance (ranging typically from tens of pico-Farad to tens of nano-Farad), even the inductance of a short BNC cable (approximately 210 nH/m or 64 nH/foot)

will form a resonant LC-circuit with the MOSFET's input capacitance. It might be necessary to dampen these resonances with added series resistors and/or RLC snubbers.

For example, a foot (30 cm) of RG-58 will resonate with a 100 pF gate capacitance at around 50 MHz and would require a 20 Ω damping resistor, while three feet of RG-58 with a 1000 pF gate capacitance part will resonate at around 9 MHz and behave reasonably with 5–10 Ω of additional damping.

The user who wishes to drive power MOSFETs is advised to experiment with different driver configurations to find the optimum combination of cable, damping and device.

3.10.4 Piezo Elements

The SIM954 output voltage limit of 10 V is too low to drive high voltage DC piezo elements. However, the module can drive piezo resonators very well. Because it has a limited output voltage, the piezo element has to be driven either by a series LC circuit, a transformer, or a combination of both. The unlimited stability will ease the impedance matching of the device to the amplifier considerably in comparison to RF amplifiers without isolation.

3.10.5 Electric Motors

The SIM954 can be used to drive small electric motors. Stepper motors and low voltage asynchronous or synchronous AC motors usually present well behaved loads and can be driven by a SIM954 as long as the average and peak current do not exceed the amplifier's specifications. Because of the fast amplifier risetimes, it is important to filter the SIM954 output with beads and small ceramic capacitors before connecting it to unshielded wires. These filters have to act on the common mode as well as the differential mode to make sure that possible high frequency components generated by the SIM954 are properly attenuated. Limiting the rise time of the driving voltages will greatly reduce possible EMI problems.

Unlike their uncommutated counterparts, DC motors which have mechanical or electronic commutators can produce voltage spikes and sudden surge currents which can degrade or damage the amplifier. They should not be connected to a SIM954 without a detailed investigation into the nature of their electric behavior and proper filtering/overvoltage protection.

4 Calibration

The SIM954 comes fully calibrated and should not exhibit major deterioration of its properties under normal operating conditions.

The user can, however, re-calibrate the module with relative ease and without excessive risk of degrading or damaging the product.

4.1 Getting Ready

The required test equipment to trim the offset voltage and current of the SIM954 is a voltmeter with 0.1 mV resolution.

4.2 Offset Voltage and Input Bias Current

Each of the two independent amplifiers of the SIM954 has one offset voltage and one input bias current trimmer. They can be accessed by removing the (right) side panel of the module which is on the side closest to the front panel LEDs.

The offset voltage and bias current trimmers R117, R198, R121 and R199 are located on the sparsely populated side of the PCB next to the two power supply limiter heat sinks. They have the following functions:

R117 - offset voltage compensation channel 1

R198 - input bias current compensation channel 1

R121 - offset voltage compensation channel 2

R199 - input bias current compensation channel 2

Since the input bias current is difficult to measure, the procedure trims the (proportional) input offset voltage instead.

Step 1: Start by connecting a mV-meter to the *input* of channel 1. The *input offset voltage* is then trimmed to 0mV with R117.

Step 2: After connecting the mV-meter to the *output* of channel 1, the *output offset voltage* can be trimmed to 0 mV with R198.

Iteration: Steps 1 and 2 are repeated as many times as necessary to trim both *input* and *output offset voltage* simultaneously to near 0 mV.

The same procedure is carried out for the second channel:

Step 3: The trim procedure starts by connecting a mV-meter to the *input* of channel 2. The *input offset voltage* is then trimmed to 0 mV with R121.

Step 4: After connecting the mV-meter to the *output* of channel 2, the *output offset voltage* can be trimmed to 0 mV with R199.

Iteration: Steps 3 and 4 are repeated as many times as necessary to trim both *input* and *output offset voltage* simultaneously to near 0 mV.

5 Parts Lists and Schematics

In This Chapter

5.1	Circuit Description	5-2
5.2	Parts Lists	5-4
5.3	Schematic Diagrams	5-7

5.1 Circuit Description

The SIM954 contains two independent amplifiers and a power conditioning circuit.

Each amplifier is primarily made out of four 250mA line driver op-amps (U101-U104 and U105-U109). The THS3091/95 family of line drivers are made by Texas Instruments using a robust 36 V RF bipolar process. Inside the small outline packages the dies are soldered to a metal pad which is exposed on the bottom side of packages. These cooling pads are directly soldered to the printed circuit board, giving the part unusual thermal load handling capability.

The SIM954 exploits this unusually powerful part by paralleling four of them with 13.2Ω output resistors (R1x6a-d). These isolation resistors give this amplifier excellent stability by adding a positive resistive component to all external passive loads. Even dead shorts and perfectly lossless capacitive and inductive loads are seen by the actual amplifier as a dissipative load that lie well within its stability limits.

Because of the load sharing each operational amplifier sees a worst case load of $13.2\Omega + Z_{Load} \times 4$. Specifically a 50Ω load therefore appears as 213.2Ω to each individual op-amp, which is a very benign load condition.

In addition, the resistors reduce the power dissipation of the op-amps in case of very low impedance loads (like shorts and DC currents into coils/transformers) driven with large currents. At 1 A output the output resistors will absorb a voltage drop of 3.2 V or approximately 20% of the total thermal load.

Because of their 3.3Ω output impedance, SIM954 amplifier channels can also be ganged in parallel if they are being driven by the same signal. See section 2.1.2 for further discussion.

The THS3091/95 are current-feedback op-amps and the ideal gain and feedback configuration at which these amplifiers have their largest useful gain-bandwidth are as inverting amplifier with a gain between -4 and -5 .

The DC gain of the amplifier is therefore chosen such that the 3.3Ω output impedance together with the 50Ω input impedance of a typical RF system form a divider which reduces the effective gain to -4 or 12 dB. This means that the module will have a gain of -4.266 into a high impedance load. This is equivalent to a 12.6 dB unterminated signal gain.

Depending on the variations in wafer lots each amplifier has a feedback of $953\text{--}1100\Omega$ (R1x4) which makes the frequency response close

to flat and leads to flat top square wave response.

To achieve the desired gain with this feedback resistance, the inverting amplifier input is connected to the input BNC through a 221–255 Ω resistor ($R1x5$). Input impedance matching is achieved with an additional resistor to ground ($R130, R131$)

Since the input offset voltage drift of the THS3091 is unsatisfactory, a slow precision amplifier ($U111, U112$) senses the average offset voltage on the inverting input nodes and corrects it by applying a correction voltage to the non-inverting power amplifier inputs. The resulting hybrid amplifier has better offset drift characteristics than the RF op-amps alone. But since the cancellation is done on the input side, and not in a second feedback loop from the output, the residual drift is higher than one would expect from an ideal hybrid op-amp.

The second artifact of the THS3091 is its high input bias current of 20 μA , which is typical for high speed bipolar amplifiers. However, since the bias current drift is only on the order of 20 nA/K, the bias current can be compensated with a constant current source. These current sources are formed by trim pots $R198, R199$ and resistors $R107, R111, R101, R119$. Additional capacitors suppress supply noise and increase common mode rejection for frequencies above approximately 6 Hz.

The output voltage of each amplifier is buffered by operational amplifiers $U201$ and $U203$. These buffers drive peak detectors $Q201/202$ and $Q203/204$.

The power supply current limiter uses MOSFETS $Q301$ and $Q302$ to limit the inrush current into capacitors $C303 - 306$. The voltage drop on sense resistors $R305$ and $R311$ opens transistors $Q305$ and $Q307$ and limits the gate voltage on the MOSFETs to approximately 750 mA. As the necessary base-emitter voltages to open $Q305$ and $Q307$ drop with higher temperature, these transistors automatically reduce the current at elevated module temperatures.

5.2 Parts Lists

The parts list is for reference only, and subject to change without notice.

Item	Quantity	Part Reference	Part Number	Value
1	32	C1x1 C1x4 C185 C186 C189 C190 C260-C267 C301-C304	5-00299-100	.1U
2	30	C102 C105 C107-C110 C112 C115 C122 C125 C132 C135 C142 C145 C152 C155 C162 C165 C172 C175 C184 C187 C188 C191 C204 C254 C311-C314	5-00525-100	1U
3	2	C192 C193	5-00525-100	1U
4	4	C201 C202 C251 C252	5-00704-100	33P
5	4	C203 C205 C253 C255	5-00387-100	1000P
6	1	C207	5-00375-100	100P
7	4	C208-C211	5-00298-100	.01U
8	2	C305 C306	5-00102-517	4.7U
9	4	C307-C310	5-00201-001	2200U
10	10	D101-D110	3-00896-145	BAV99
11	2	D111 D305	3-01357-142	MMBZ5230
12	1	D203	3-00544-145	BAV70LT1
13	3	D204-D206	3-00424-160	GREEN, 3MM SUBM
14	4	D301-D304	3-00479-040	MUR410
15	1	J102	7-00966-721	BNCBARRELSIM914
16	4	J103 J201 J202 J301	1-00471-002	4 PIN, WHITE
17	1	J105	1-00109-000	4 PIN DI
18	1	JP103	1-00367-040	15 PIN D
19	7	L101-L103 L301-L304	6-00174-051	BEAD
20	4	Q201 Q202 Q251 Q252	3-00810-150	MMBTH10LT1
21	4	Q203 Q204 Q253 Q254	3-00809-150	MMBTH81LT1
22	6	Q205 Q206 Q208 Q209 Q255 Q256	3-01153-360	NDC7002N
23	3	Q207 Q305 Q307	3-00601-150	MMBT3904LT1
24	1	Q301	3-00944-053	IRF4905
25	1	Q302	3-00283-053	IRF530/IRF532
26	3	Q303 Q304 Q306	3-00580-150	MMBT3906LT1
27	8	R101 R107 R109 R111 R119 R120 R194 R195	4-01280-110	49.9K
28	8	R102 R112 R122 R132 R142 R152 R162 R172	4-01447-100	47
29	8	R103 R113 R123 R133 R143 R153 R163 R173	4-00925-110	10
30	8	R104 R114 R124 R134 R144 R154 R164 R174	4-01115-110	953
31	8	R105 R115 R125 R135 R145 R155 R165 R175	4-01054-110	221
32	8	R106 R116 R126 R136 R146 R156 R166 R176	4-02468-110	3.3
33	8	R108 R118 R128 R138 R148 R158 R168 R178	4-01165-110	3.16k
34	4	R117 R121 R198 R199	4-00611-053	100K
35	2	R130 R131	4-01090-110	523
36	10	R180-R187 R196 R197	4-00993-110	51.1
37	2	R201 R251	4-01174-110	3.92K
38	2	R202 R252	4-01448-100	51
39	4	R203 R204 R253 R254	4-01163-110	3.01K
40	12	R205-R208 R218 R233 R237 R241 R255-R258	4-01117-110	1.00k
41	4	R209-R212	4-01575-100	10M
42	6	R213-R215 R263-R265	4-01551-100	1.0M
43	2	R216 R266	4-01120-110	1.07K
44	4	R217 R232 R236 R240	4-01222-110	12.4K
45	4	R219 R234 R238 R242	4-00992-110	49.9
46	4	R220 R235 R239 R243	4-01128-110	1.30K

47	1	R221	4-01246-110	22.1K
48	4	R223 R224 R230 R231	4-01483-100	1.5K
49	1	R227	4-01486-100	2.0K
50	4	R259-R262	4-01575-100	10M
51	4	R301 R302 R308 R309	4-01431-100	10
52	11	R304 R307 R313-R319 R329 R330	4-01185-110	5.11K
53	2	R305 R311	4-00537-020	1.0
54	3	R306 R312 R328	4-01527-100	100K
55	8	R320-R327	4-00935-110	12.7
56	10	U101-U108 U201 U203	3-01669-360	THS3091/5
57	2	U111 U112	3-01360-120	OPA228UA
58	4	U202 U204-U206	3-00653-360	AD8561
59	1	U207	3-00662-103	74HC14
60	1	U303	3-00709-130	78L05
61	1	U304	3-00712-130	79L05

5.3 Schematic Diagrams

Schematic diagrams follow this page.