

Choosing a Quadrupole Gas Analyzer

Application Note #9

Modern-day contamination control requirements for gas phase processes are constantly pushing the limits of performance of quadrupole gas analyzers. The quadrupole technology is rapidly evolving and adapting to lower contamination level specifications. A good understanding of the various factors affecting the detection capabilities of the different gas analysis systems currently available is an essential tool when selecting a sensor for a specific application. As is usually the case, most choices involve compromises, and a good understanding of the basic tradeoffs associated with different detector configurations will minimize mistakes and maximize productivity.

All gas phase processing setups can benefit from the addition of a quadrupole gas analyzer. The information delivered by a well-matched detector rapidly becomes an integral part of the process, dramatically reducing the amount of guesswork that has traditionally been part of most vacuum troubleshooting procedures. As quadrupole gas analyzers become more affordable, they are rapidly becoming commonplace in all industries that require strict control of contamination levels in process gases. A smart software interface, lower detection limits and reduced cost of ownership are some of the features to look for in modern instruments.

The following sections of this article describe the performance specifications of open and closed ion source quadrupole mass spectrometers. The main objective of this information is to introduce the basic concepts required to choose the right analyzer for any gas phase application, and also to present some of the basic operating principles that must be kept in mind to assure the optimum performance of the instrument selected.

Residual Gas Analyzers

The prototypical residual gas analyzer (RGA) has an open ion source (OIS) and is mounted directly on a vacuum chamber so that the entire sensor is at the same pressure as the rest of the vacuum system. Small physical dimensions make it possible to attach an RGA to virtually any vacuum system, including both research and process setups. The maximum operating pressure is 10^{-4} Torr. Minimum detectable partial pressures (typically measured for N_2 at 28 amu) are as low as 10^{-14} Torr for units equipped with an electron multiplier.

In high vacuum applications such as research chambers, surface science setups, accelerators, aerospace chambers, scanning microscopes, outgassing chambers, etc., RGAs are effectively used to monitor the quality of the vacuum, and they can easily detect even the most minute impurities in the low pressure gas environment. Trace impurities can be measured down to 10^{-14} Torr levels, and sub-ppm detectability is possible in the absence of background interferences. During system troubleshooting, RGAs are also used as very sensitive, in-situ, helium leak detectors.

In the semiconductor industry, RGAs are best used in evaporators, sputterers, etchers or any other high vacuum systems that are routinely pumped down to lower than 10^{-5} Torr. Their main application is to check the integrity of the vacuum seals and the quality of the vacuum before any wafers are committed to the process. Air leaks, virtual leaks and many other contaminants at very low levels can easily ruin wafers and must be detected before a process is initiated. As the semiconductor processes become more sophisticated, they also become less tolerant to contaminants. Residual gas analysis in a process chamber increases up-time and production yield, and reduces cost of ownership.

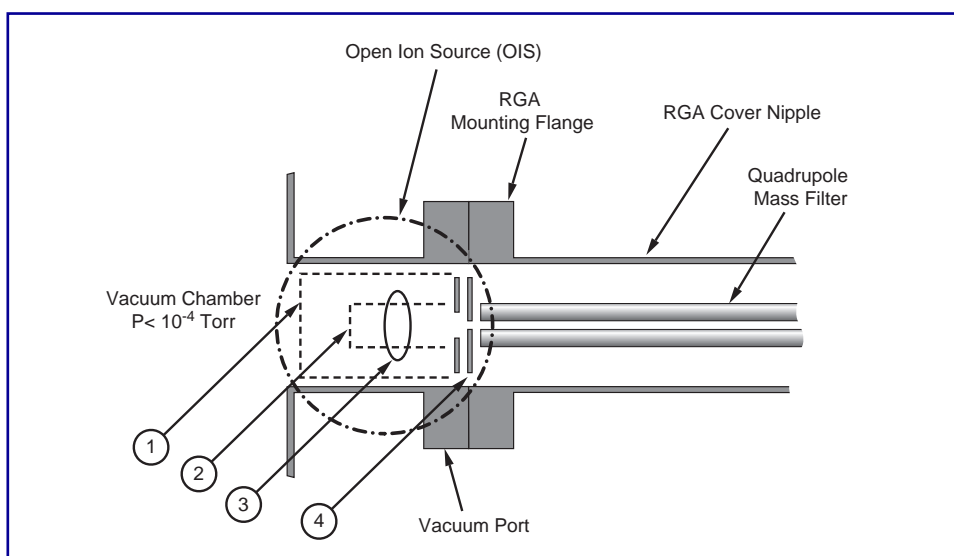

Figure 1: Schematic diagram of OIS

The Open Ion Source (OIS)

The standard ion source used in most commercially available RGAs is the open ion source (OIS). This ionizer is considered the "do it all" source for RGAs. It has been around, in its cylindrical, axially symmetrical version, since the early 1950's. A schematic of a generic OIS design is shown in Figure 1.

The OIS penetrates into the process chamber. The filament wire and the anode wire cage are "open" to the surrounding vacuum chamber. All molecules that are present in the vacuum chamber can easily move through the ion source. The pressure in the ionizer is the same as in the rest of the surrounding vacuum, and also the same as in the quadrupole mass analyzer and ion detector. The OIS is "open" to all the gaseous molecules in the vacuum chamber. It can be used to monitor and detect changing gas levels, as long as the overall pressure remains under 10^{-4} Torr. Higher pressures result in a decrease in sensitivity due to space charge repulsion between ions.

Performance Limitations of the OIS

OIS RGAs do an excellent job at measuring residual gas levels without affecting the gas composition of their vacuum environment. However, some potential problems must be kept in mind, particularly when the sensor is used routinely to monitor minute trace impurities (ppm and sub-ppm levels) or ultra-high vacuum (UHV, $<10^{-9}$ Torr) environments.

The following is a list of the different ways in which an OIS RGA can contribute to its background signals, affecting the detection capabilities of the sensor. Methods to minimize these problems are described whenever applicable.

Outgassing

The OIS is a hot-cathode ion source. The filament wire (cathode) must be heated to high temperatures (>1300 °C) in order to establish an electron emission current. In the high vacuum, most of the energy required to heat the filament is dissipated to the surroundings through radiative processes. As a result, the entire ionizer and the adjacent walls "run hot". The elevated temperatures result in increased outgassing from the OIS itself, and from the adjacent chamber walls. The gases emitted by outgassing can degrade the minimum detectable partial pressure (MDPP) of the OIS RGA for many important species, including H_2 , H_2O , N_2 , CO and CO_2 .

Outgassing from a hot cathode gauge is not a new problem for high-vacuum users. It is also present in the Bayard-Alpert ionization gauges that have been commonplace in vacuum chambers for the last 50 years. In most cases, outgassing simply affects the composition of the gas mixture being measured. However, under some circumstances, outgassing can be a serious problem and even affect the outcome of experiments or processes. Degassing the ionizer can help minimize some of the background signals; however, this usually only works as a temporary solution.

Some RGA vendors offer UHV versions of their OIS with anodes (and sometimes entire ionizer assemblies) made out of

platinum clad molybdenum wire. This highly inert material exhibits decreased adsorption for many gases and provides reduced outgassing and ESD.

Water outgassing is a frequent interference, especially important because it is a serious source of contamination in many high-vacuum processes. Overnight bakeouts at greater than 200 °C are the best option to minimize water outgassing from an OIS RGA.

H_2 outgassing from the OIS electrodes can be a concern for users operating in the UHV regime, where residual hydrogen typically amounts to as much as 95 % of the total gas mixture composition. H_2 is dissolved in most varieties of 300 series stainless steel and can readily outgas from the hot OIS electrodes. The contribution of the OIS to the H_2 background depends on its composition and can be dramatically reduced using platinum clad components. In all cases, the effect diminishes with time as the gas is depleted from the electrodes.

Electron Stimulated Desorption (ESD)

Even after an RGA has been thoroughly baked out, peaks are frequently observed at 12, 16, 19 and 35 amu, which are formed by ESD from surfaces within the OIS rather than by electron-impact ionization of gaseous species. ESD affects the RGA performance in a way similar to outgassing.

Several steps can be taken to minimize the effect:

- * *Degassing with high electron energies—usually an option in commercially available instruments*
- * *Gold plating the ionizer—decreases the adsorption of many gases and hence reduces the ESD effect. Using platinum clad molybdenum ionizers is also an alternative.*
- * *Reducing the extent of the electron beam.*
- * *Reducing the surface area of the OIS—for example, use wire mesh instead of solid perforated metal*
- * *Avoid exposing the ionizer to chlorinated and fluorinated compounds.*

Background Interference

The quadrupole mass filter assembly has a large surface area in comparison to the ionizer, and even though it does not get as hot as the ionizer during operation, it can still outgas. The fact that the OIS is exposed to the same vacuum environment as the rest of the sensor makes the ionizer sensitive to the impurities outgassed by the rest of the quadrupole assembly. A serious problem for a lot of RGA users (particularly in the UHV range) is H_2O outgassing from unbaked RGAs. However, lots of other species can also affect the background readings. For example, high Ar backgrounds can be expected if the sensor was recently exposed to large levels of the gas (since it tends to get adsorbed on SS surfaces and desorbs only very slowly).

The ionizer is also sensitive to impurities generated at the hot filament. Gas molecules can suffer thermal cracking and chemical reactions at the filament surface, and the products of

the reaction can easily find their way into the ionization region. The impurities generated in this fashion are usually an important source of contamination of the ionizer's surfaces and have a serious effect on the RGA's long-term stability. For example, CO and CO₂ are emitted by most hot filaments and easily find their way into the ionizer and vacuum system.

Regular bakeouts are the most efficient way to minimize this problem. An overnight bakeout at 200 °C will usually take care of most contamination problems. If the problem persists, it might be necessary to clean and/or refurbish the quadrupole sensor.

Partial Pressure Reduction (PPR) systems

RGAs are not limited to the analysis of gases at pressures below 10⁻⁴ Torr. Higher gas pressures can be sampled with the help of a differentially-pumped, pressure-reducing gas inlet system (PPR), consisting of a restriction and a vacuum pump package. Common restrictions are pinholes and capillaries, which can provide pressure reductions of more than six decades of pressure. Vacuum pump packages typically consist of a turbomolecular pump backed by a foreline pump. The combined RGA, gas inlet system, and pumping station constitute what is usually referred to as a Partial Pressure Reduction (PPR) System. These gas sampling systems are commonplace in gas phase processes and are available from several RGA vendors. Properly designed, PPRs can monitor processes from beginning to end, providing essential information every step of the way.

The PPR system depicted in figure 2 is an example of a typical pressure reduction setup used to step process pressures down to levels acceptable to the OIS RGA. The PPR contains two inlet paths to the RGA: a high conductivity path (Hi-C) for monitoring base vacuum, and a low conductivity path (Lo-C) for monitoring gases at operating pressure.

The high conductivity path is used when the vacuum system is at pressures below 10⁻⁴ Torr. At high vacuum, typical applications are leak testing and monitoring the ultimate vacuum of the chamber. For example, in a sputtering chamber, the first stage of the process is a pump-down to less than 10⁻⁶ Torr. At this point the RGA may be used to check the quality of the background for leaks and contaminants. Once the quality of the vacuum is satisfactory, the sputtering chamber is backfilled with argon at a few mTorr and sputtering is started.

The low conductivity path is used when the process chamber is at pressures above 10⁻⁴ Torr. This path contains a micro-hole orifice which reduces the pressure several decades to a level suitable for the RGA (typically around 10⁻⁵ Torr). Apertures are available for operating pressures as large as 10 Torr. An array of apertures (or an adjustable metering valve) are sometimes used to adjust the pressure reduction factor to different pressures along the process. For example, during a sputtering process, the Lo-C path may be used to monitor water vapor and hydrocarbon levels to assure they do not exceed certain critical levels that degrade the quality of the sputtered films.

A pair of pumps draws the gas through the aperture to the RGA establishing the pressure drop. The pumps used in these systems are usually very compact, oil-free and low maintenance.

For pressures higher than 10 Torr, the gas flow rate into the sample inlet side of a single-stage PPR (such as shown in Figure 2) becomes extremely small, and the time response is too slow for any practical measurements. In those cases, a dual-stage bypass pumped gas-sampling system, with a much larger gas flow rate and faster response, is a better choice than a single-stage PPR. Bypass pumped gas-sampling systems, with medium pressure intermediate stages that are capable of analyzing gas mixtures up to several atmospheres, are available from several RGA vendors.

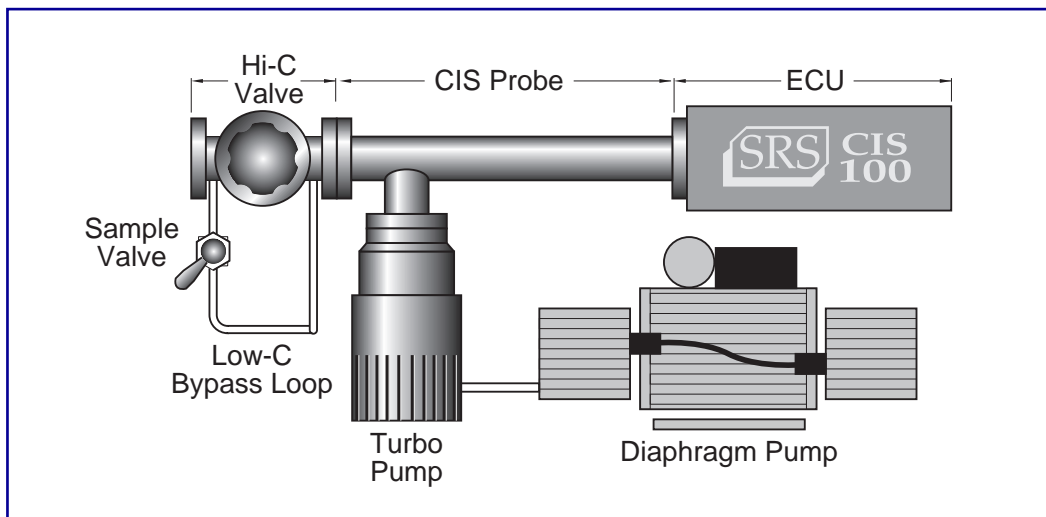

Figure 2: PPR inlet system

Performance Limitations of PPR Systems

PPRs do an excellent job sampling gases at pressures below 10 Torr. The information they provide is routinely used to diagnose and control gas phase processes in a large variety of industries. As prices drop and the technology evolves, the instruments are continuously finding new fields of application.

A large number of PPR systems are dedicated to the detection of trace impurities in gas mixtures. OIS RGAs have adequate sensitivity and dynamic range to detect part-per-million (ppm) level contaminants. However, interferences from process gases and background interferences from the sensor itself can make the detection of ppm levels of impurities with a PPR difficult in practice.

Background Interferences

The background gases present in the analyzer chamber can obscure the MDPPs of some important gases (H_2 , H_2O , N_2 , CO and CO_2). Background gases are due to outgassing, electron stimulated desorption, and the finite compression ratio of the pumping system.

In order to best illustrate this point, consider as an example, the analysis of water in a 10^{-2} Torr Ar sputtering process. During process monitoring, the mass spectrometer typically runs at about 10^{-5} Torr, corresponding to a three-decade reduction factor across the Lo-C path of the PPR. The pressure drop brings 1 ppm of water in the process chamber to a partial pressure in the mass spectrometer of about 10^{-11} Torr (well within the detection limit of a typical RGA). However, with the mass spectrometer isolated from the process gases, the residual pressure in the PPR chamber is, at best, in the order of 10^{-9} Torr (with most of that being water). This water level is one hundred times larger than the 10^{-11} Torr corresponding to a ppm of water in the process chamber, meaning that the water vapor concentration cannot be reliably detected or measured to better than 100 ppm under these "common" operating conditions.

The MDPP limit could be improved to 20 ppm increasing the operating pressure in the RGA chamber to 5×10^{-5} Torr during analysis. However, even a 20 ppm MDPP limit for water might not be low enough in some cases. The addition of a cryopump, with a large pumping speed for water, has been proved to dramatically minimize the water background in the PPR's quadrupole chamber. However, this is rarely done in practice because of the high cost of the pump. The same limitations must be kept in mind for other potential interfering gases. In order for any species to be detectable at the ppm level (10^{-8} Torr in a 10 mTorr process), the residual mass spectrum for the PPR must show pressure readings of less than 10^{-11} Torr at the mass values corresponding to the peaks of that species. Such levels are not easily achieved in most vacuum system unless the necessary precautions are taken to minimize all sources of contamination. The problem is usually more serious for masses under 50 amu where there are always background peaks in the residual mass spectrum.

Even though the RGA is intrinsically capable of performing sub-ppm measurements, it is not always easy to find places in the residual mass spectrum of the RGA where the background is at ppm levels.

A common source of background interference in PPRs is contamination from pump oil backstreaming into the PPR chamber from conventional, oil-based, roughing pumps. Switching to a completely oil-free pumping station eliminates this problem.

The MDPP limit for air is usually limited by the compression ratio of the pumping station. In most PPR systems, the N_2 levels are usually under 10^{-9} Torr, with oxygen levels approximately five times lower. This corresponds to MDPP levels of better than 20 ppm for N_2 @ 28 amu and 4 ppm for O_2 @ 32 amu in a 10 mTorr process.

Hydrogen is generally impossible to detect at ppm levels because it outgasses readily from the analyzer, and it is not effectively pumped by most turbo pumps. Some of the tricks that are used to minimize the H_2 background signals include: using a Pt Clad Molybdenum OIS, and the addition of a special pumping station with increased pumping speed for hydrogen.

Process Gas Interference

The other limitation to ppm detection levels in a typical OIS RGA based PPR system is caused by interference from the same process gases that are being analyzed.

The best way to illustrate this point is to go back to the example of water analysis in the 10 mTorr Ar sputtering process. We saw that detecting water at better than 20 ppm levels is very difficult unless the PPR chamber is very carefully baked out and protected from water contamination. However, as we will see, this is only part of the problem: there is also a serious interference at m/e 18 from the same Ar used in the sputtering system. The isotope ^{36}Ar is present at 0.34%. In the electron ionization process, doubly charged argon is formed leading to peaks at m/e 20 ($^{40}Ar^{++}$) and m/e 18 ($^{36}Ar^{++}$). For 70 eV electron impact energy, a typical level of $^{36}Ar^{++}$ is 350 ppm. Therefore, if you want to detect ppm levels of water in an Ar based sputtering system, you must solve two problems: background contribution of water outgassing from the sensor and interference at m/e 18 from $^{36}Ar^{++}$.

A thorough bakeout can reduce the background water contribution to the low tens-of-ppm levels, but eliminating the $^{36}Ar^{++}$ interference requires the use of several tricks. Some manufacturers simply choose to monitor the m/e 17 peak due to the $[OH]^+$ water fragment. For 70 eV ionizing electrons, this peak is four times smaller than the main one at 18 amu. This results in a significant reduction in sensitivity for water detection. It also adds the problem of abundance sensitivity while trying to measure the mass 17 intensity next to a large $^{36}Ar^{++}$ peak at 18 amu.

A better option (and the one recommended for RGAs with programmable ionizer voltages) is to operate the ionizer with

the electron impact energy reduced to less than 40 eV. This ionization energy is below the appearance potential (43.5 eV) of Ar^{++} . For example, the peaks at masses 18, 19 and 20 due to Ar^{++} disappear while operating an RGA with 35 eV electrons, and this is achieved with minimal reduction in the sensitivity of detection of Ar^+ at 36, 38 and 40 amu.

Different electron ionization energies are routinely used to selectively ionize species in a gas mixture. Tables with ionization potentials for many different gases are readily available from the general mass spectrometry literature. Reduction of the electron energy usually imposes an extra load of work on the filament and can reduce its lifetime. However, the reduced interference effects offset the extra costs of filament replacement.

The Closed Ion Source (CIS)

In applications requiring the measurement of pressures between 10^{-4} and 10^{-2} Torr, the problem of background and process gas interferences can be significantly reduced by replacing the traditional OIS PPR configuration with a closed ion source (CIS) sampling system. A cross section of a generic CIS setup is shown in Figure 3.

The CIS Ionizer sits on top of the quadrupole mass filter replacing the more traditional OIS used in conventional RGAs. It consists of a short, gas-tight tube with two very small openings for the entrance of electrons and the exit of ions. Electrons enter the ionizing region through an entrance slit of small dimensions. The ions are formed close to, and attracted by, a single extraction plate and exit the ionizer through a circular aperture of small diameter. Alumina rings seal the tube from the rest of the quadrupole mass assembly

and provide electrical insulation for the biased electrodes. Ions are produced by electron impact directly at the process pressure.

A pumping system, similar to the one used in PPR systems, keeps the filament and the rest of the quadrupole assembly at pressures below 10^{-5} Torr (two decades of pressure reduction). The design is very simple and was successfully applied for many years to gas chromatography mass spectrometry instruments before it was adopted by quadrupole gas analyzers. Most commercially available CIS systems are designed to operate between 10^{-2} and 10^{-11} Torr, and offer ppm level detectability over the entire mass range for process pressures between 10^{-4} and 10^{-2} Torr.

Differences Between the PPR and CIS Systems

An understanding of the performance differences between the CIS setup and the more traditional OIS RGA based PPR is indispensable when choosing the sensor setup that is best suited for a particular process application. Process engineers should carefully weight all differences before selecting an analyzer configuration for their application.

Direct Sampling

The CIS anode can be viewed as a high conductance tube connected directly to the process chamber. The pressure in the ionization area is virtually the same as that in the process chamber. The CIS ionizer produces ions by electron impact directly at process pressure, while the rest of the mass analyzer and the filament are kept under high vacuum. Direct sampling provides good sensitivity (due to the large ion densities available) and fast response times. The "memory

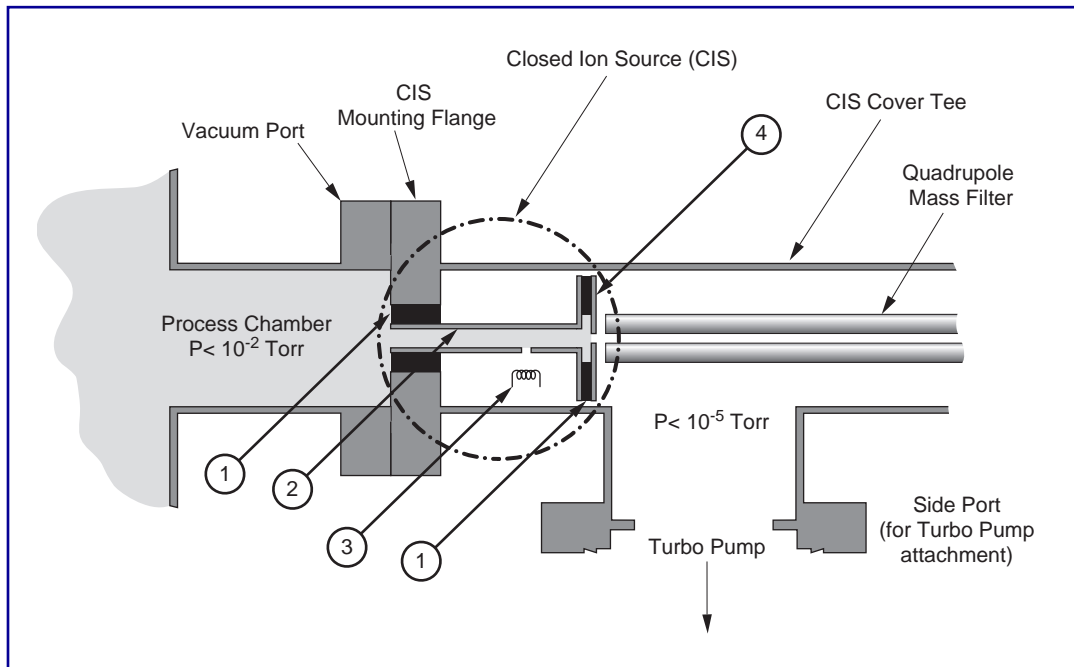

Figure 3: Schematic diagram of the CIS

effects", typically associated to pressure reduction and conductance orifices, are significantly reduced. Also, the fractionation effects due to the molecular weight dependent diffusivities of the different gas molecules through the PPR apertures are absent.

Signal-to-Background Ratios

Because the sampling pressure in the CIS is typically two decades higher than that of the rest of the sensor's vacuum system, the signal-to-background ratio is significantly increased relative to the OIS PPR systems. This is particularly important when measuring common residual gases, such as water. In order to illustrate this point, we go back to the water measurement example in a 10^{-2} Torr Ar sputtering process. The Ar gas is ionized directly at 10^{-2} Torr (three orders of magnitude higher than in the OIS PPR!) but in the same background (10^{-9} Torr) of residual water. This residual water signal now corresponds to a 100 ppb MDPP level for water in the CIS system. This is quite an improvement over the OIS PPR performance!

The combination of direct sampling and differential pumping provides the potential for ppm and sub-ppm detection limits for even the most pervasive residual gases. For other common interferences, such as organic contaminants or reaction by-products of the filament, the gas tight design of the source reduces the visibility of the ionization region to those gases providing a very clean residual gas spectrum, free of many of the spectral overlaps that are common in OIS PPR setups.

Interference from contaminants generated by ESD is also reduced in the CIS because a much smaller electron beam penetrates the ionizing volume. In addition, the inside walls of most commercially available CISs are coated with highly inert materials such as gold, platinum clad and pure molybdenum which adsorb less impurities than stainless steel.

The ability of the CIS to sample gases directly in the mTorr range, and to provide ppm level detectability across its entire mass range, has made CIS systems the instrument of choice in semiconductor processing applications such as PVD, CVD and etching.

Ionizer Contamination

In an OIS PPR system, sample molecules that have suffered thermal cracking or chemical reaction at the filament, are free to drift into the ionization region. This is a very significant source of surface contaminants for electron impact ionizers. In contrast, the gas tight design of the CIS reduces the visibility of the source to those contaminant gases, providing reduced contamination and better long-term stability. Most CIS manufacturers utilize exclusively tungsten filaments in their systems. W resists many corrosive gases (such as WF_6) and reactive gases (such as Silane) minimizing reactions at the filament that contribute to the background, also resulting in extended filament lifetime.

Versatility

When properly matched to a process, both OIS PPR and CIS systems are very versatile instruments that provide crucial information throughout an entire gas phase process. A PPR system, fitted with a dual path gas inlet, can switch effortlessly from a highly sensitive RGA mode of operation, to a process monitoring mode by simply switching from the Hi-C to the Lo-C sample paths.

Different modes of operation can also be easily achieved in a CIS by simply changing some of the sensor's ionization parameters. A CIS gas analyzer, even though not as sensitive as an RGA, can tackle most residual gas analysis and leak checking tests that are required in process chambers. The sensitivity of the CIS is reduced over the OIS because of the very small holes for electron entrance and ion exit. However, in most cases, running the electron multiplier at higher gain levels than the RGA makes up the reduction in sensitivity. Typical MDPP values for CIS systems, fitted with an optional electron multiplier and operated in the RGA mode, are in the order of 10^{-11} Torr. This is about two decades higher than the MDPP values that can be achieved with PPRs operated in the RGA mode with the Hi-C sampling path open.

The CIS ionizer can also be reconfigured for on-line process monitoring and control, and verification of process gas purity at the point of use. The electron emission current is raised during residual gas analysis to increase sensitivity, and reduced during process monitoring to avoid space charge saturation effects in the ionizing volume at the higher pressures.

The tight design of the CIS makes it possible to operate the ionizer at lower electron ionization energies than are possible with OISs. Most of the commercially available CIS systems offer at least two electron energy settings of 70 and 35 eV. The 70 eV setting is mostly used for leak testing and routine gas analysis. The spectra collected are virtually identical to those obtained with standard RGAs. The 35 eV setting is used during process monitoring to eliminate process gas interference peaks. A common application of the low energy mode is to the elimination of the doubly ionized ${}_{36}Ar^{++}$ peak that interferes with water detection at 18 amu in sputtering processes. CIS systems with user programmable ionizer voltages offer the highest versatility, since they can be configured to selectively ionize species in a gas mixture by carefully adjusting the electron impact energy.

High Pressure Sampling with a CIS Gas Analyzer

CIS analyzers can sample gases directly up to about 10^{-2} Torr pressure levels. The upper pressure limit is set by the reduction in mean free path for ion-neutral collisions, which takes place at higher pressures, and results in significant scattering of ions and reduced sensitivity. However, operation is not limited to the analysis of gases at pressures below 10^{-2} Torr. Higher gas pressures can be sampled with the help of a differentially pumped pressure reducing gas inlet system (PPR), just as it is done with conventional RGAs. A pressure reducing gas inlet system, matched to the conductance of the

CIS analyzer, will allow the sensor to sample gas pressures as large as 10 Torr. As in the case of the PPR systems, the penalty paid is reduced sampling speed, fractionation of the gas mixture at the sample inlet, and possible memory effects at the ionizer.

For pressures higher than 10 Torr, the gas flow rate into the closed ionizer becomes extremely small, and the time response is too slow for any practical measurements. In those cases, a bypass pumped gas-sampling system, with a much larger glass flow rate and faster response, is a much better choice than a single restriction into the CIS ionizer.

Conclusions

Any vacuum processing setup can benefit from the addition of a quadrupole gas analyzer. A good understanding of the different factors affecting the performance of the different quadrupole gas analysis systems currently available, is an essential tool when selecting the best sensor configuration for any application. Quadrupole gas sampling systems are available from several different manufacturers and it is often difficult to decide which one constitutes the best match for a process. In most cases, there is more than one way to set up the measurements, and each choice involves compromises. A good understanding of the basic differences between the available options minimizes problems and maximizes productivity.

As quadrupole gas analyzers become more affordable, they will become commonplace in all industries requiring the strict control of contamination levels in process gasses.